

AIN FRAME AND COVER PARTS FOR 9910,9920  
機體機構和護蓋零件

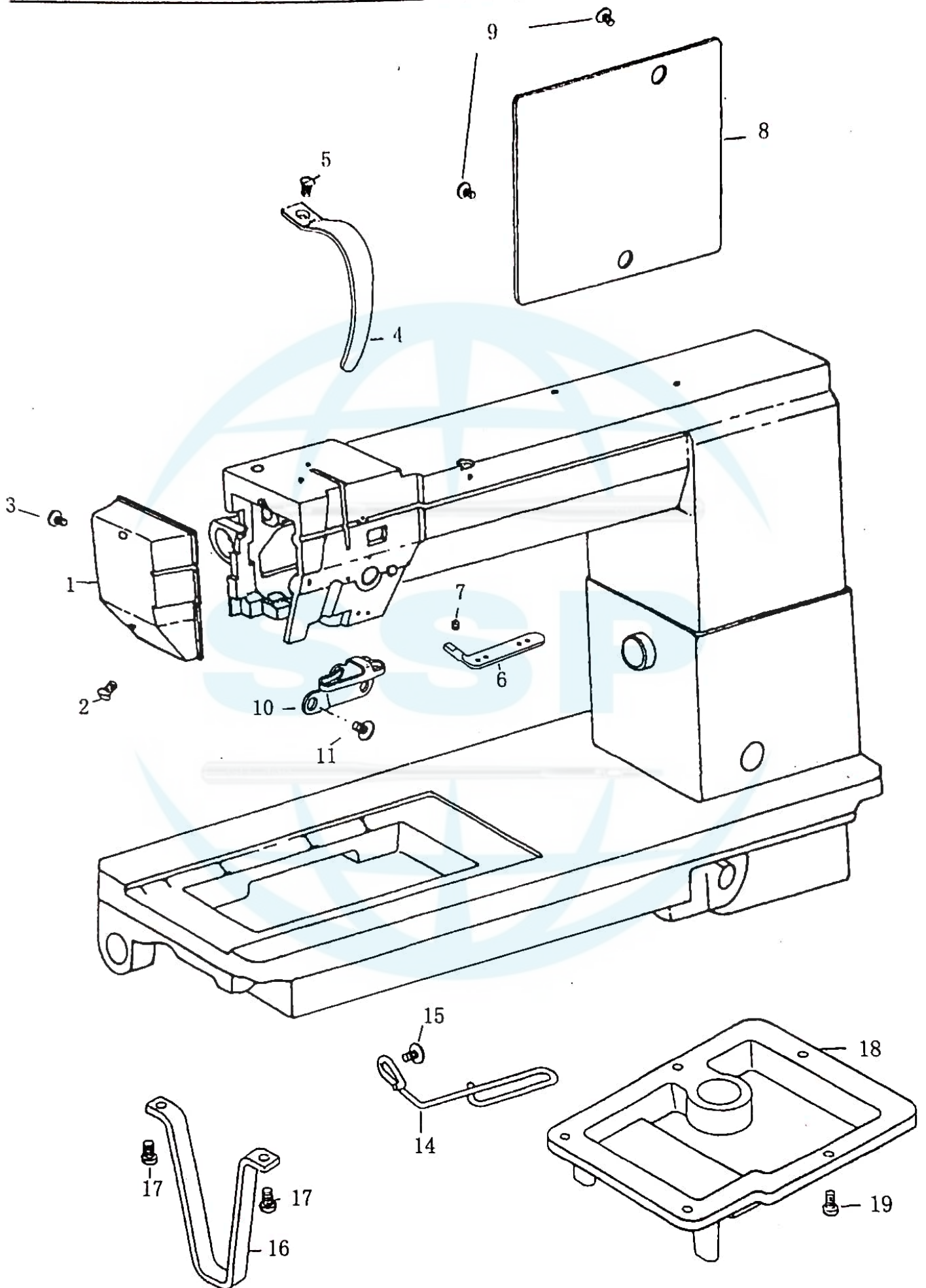

MAIN FRAME AND COVER PARTS FOR 9910,9920  
本體機構和護蓋零件

Ref.No	Part No.	Name of Part	Amt.req.		Remarks
			9910	9920	
1	119687	Face Plate 面蓋	1	1	
2	108246	Screw 螺絲	1	1	
3	108234	Screw 螺絲	1	1	
4	168061	Thread Take-up Cover 天秤蓋	1	1	
5	210210	Screw 螺絲	1	1	
6	119027	4 Hole Thread Retainer 四孔過線桿	1	1	
7	314946	Screw 螺絲	1	1	
8	119039	Arm Side Cover 大防砂板	1	1	
9	700335	Screw 螺絲	2	2	
10	118430	Thread Guide Wire 過線桿	1	1	
11	700335	Screw 螺絲	1	1	
14	119686	Thread Guide Wire 過線桿	1	1	
15	700335	Screw 螺絲	1	1	
16	119092	Bracket 固定腳器	1	1	
17	108285-1	Screw 螺絲	2	2	
18	119091	Bottom Cover 底座盤	1	1	
19	108225	Screw 螺絲	5	5	

# THREAD TENSION MECHANISM FOR 9910,9920

## 縫線調整機構

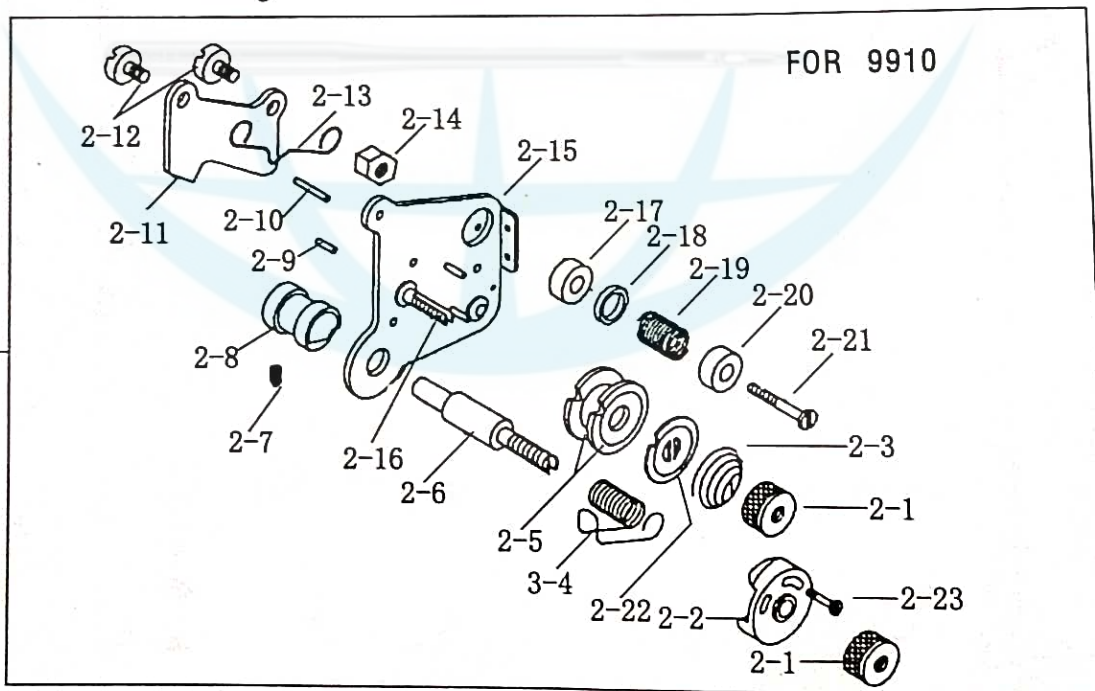
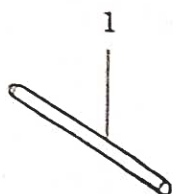
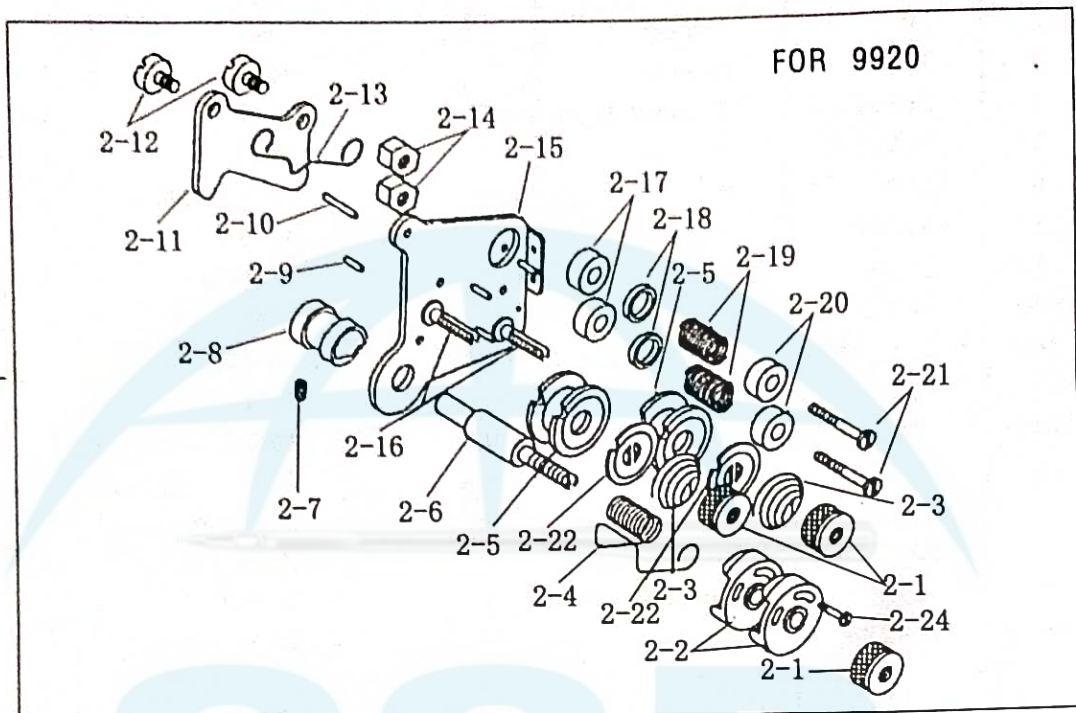

3



THREAD TENSION MECHANISM FOR 9910,9920  
縫線調整機構

Ref.No	Part No.	Name of Part	Amt.req.		Remarks
			9910	9920	
1	118553	Tension Releasing Pin	1	1	(3-1~21)
2	119171	Thread Tension Regulator Assy.	0	1	
2-1	119171-1	Nut	2	2	
2-2	119171-2	Spring Guide Assy	1	2	
2-3	119171-3	Tensin Spring	1	2	
2-4	119171-4	Thread Take-up Spring	1	1	
2-5	119171-5	Tension Disc	2	4	
2-6	119171-6	Thread Tension Stud	1	1	
2-7	119171-7	Screw	1	1	
2-8	119171-8	Thread Tension Regulator Bushing	1	1	
2-9	119171-9	Tension Releasing Pin	1	1	
2-10	119171-10	Tension Releasing Pin	1	1	
2-11	119171-11	Tension Release Plate	1	1	
2-12	119171-12	Screw	2	2	
2-13	119171-13	Tension Release Spring	1	1	
2-14	119171-14	Nut	1	1	
2-15	119171-15	Upper Thread Tension Plate	1	1	
2-16	119171-16	Thread Tension Stud	1	2	
2-17	119171-17	Thread Guide Bracket	1	2	
2-18	119171-18	Thread Guide Disc	1	2	
2-19	119171-19	Thread Guide Spring	1	2	
2-20	119171-20	Thread Guide Cap	1	2	
2-21	119171-21	Screw	1	2	
2-22	119171-22	Tension disc Washer	1	2	
2-23	119171-23	Screw	1	0	
2-24	119171-24	Screw	0	1	
3	119766	Thread Tension Regulator Assy.	1	0	(3-1~21)
3-4	119766-1	Thread Take-up Spring	1	0	
4	175096-1	Screw	1	1	
5	700412	Screw	1	1	
6	700412-1	Bushing	1	1	



THREAD TENSION MECHANISM FOR 9910,9920  
 縫線調整機構

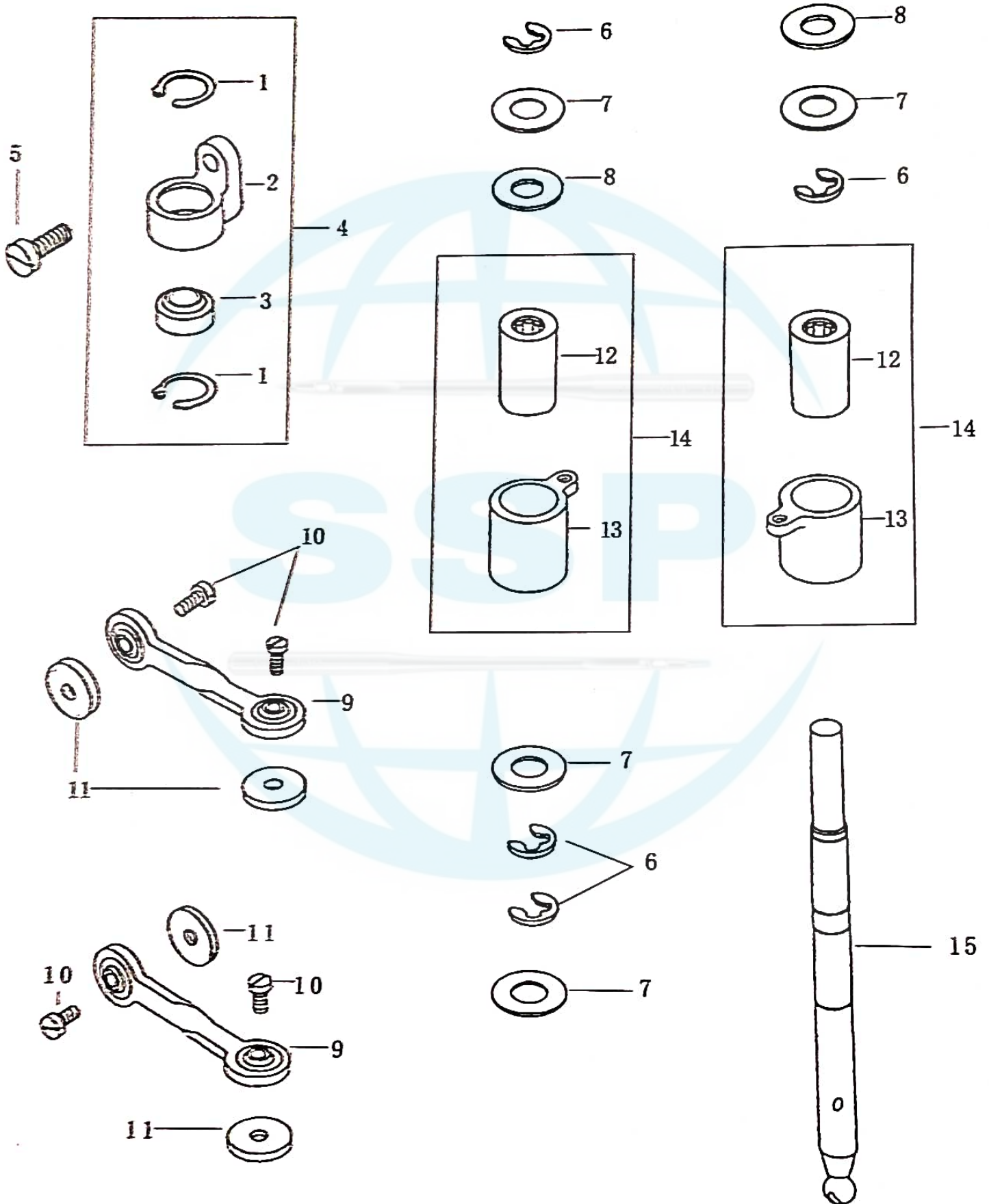

SINGLE DIRECTION BEARING SHAFT MECHANISM  
單向培林軸機構

Ref.No	Part No.	Name of Part	Amt.req.		Remarks	
			9910	9920		
1	660290	Retaining Ring	C型扣環	2	2	
2	119158	Bearing Bracket	萬向培林座	1	1	
	119158-1	Bearing Bracket	(for · MS-119803)	1	1	
3	756901	Bearing	培林	1	1	
4	119150	Bearing Set	萬向培林組	1	1	(1~3)
	119150-1	Bearing Set	(for · MS-119150)	1	1	
5	108294	Screw	螺絲	1	1	
6	640210	E-Ping	E型扣環	4	4	
7	119159	Washer(1.0)	華司	2	2	
7-1	119160	Washer(1.4)	華司	2	2	
8	119886	Washer(0.1)	華司	2	2	
8-1	119961	Washer(0.15)	華司	2	2	
8-2	119962	Washer(0.2)	華司	3	3	
8-3	119963	Washer(0.05)	華司	2	2	
9	119507	Link	萬向連杆	2	2	
10	174176	Ssrew	螺絲	4	4	
11	119087	Oil Felt	油棉墊	4	4	
12	061014	Needle Bearing	針狀培林	2	2	
13	119505	Free-Wheeling	單向培林座	2	2	(12, 13)
14	119506	Free Bearing	單向培林組	2	2	
15	119503	Shaft	單向培林軸	1	1	

ROLLER PRESSER FOOT MECHANISM FOR 9910,9920  
 輪錢組機構

1 (Large)

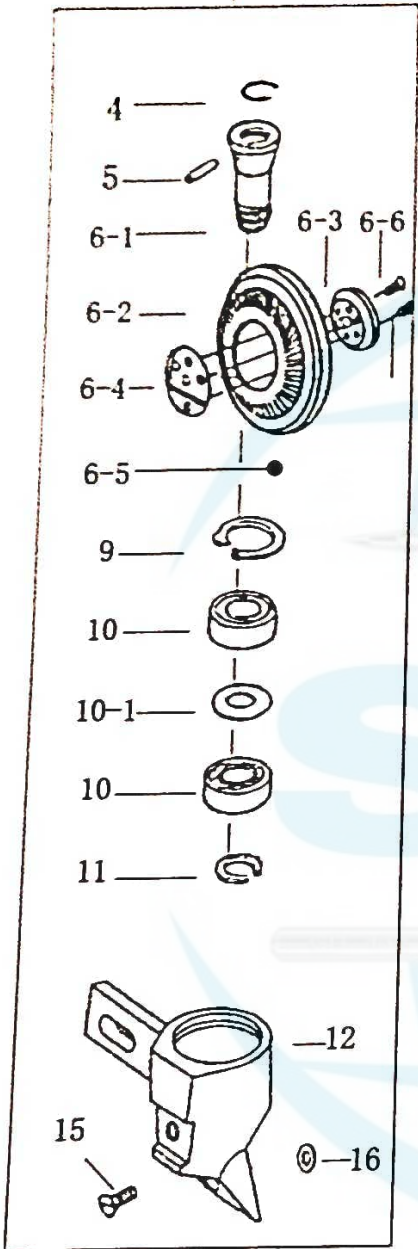

2 (Middle)

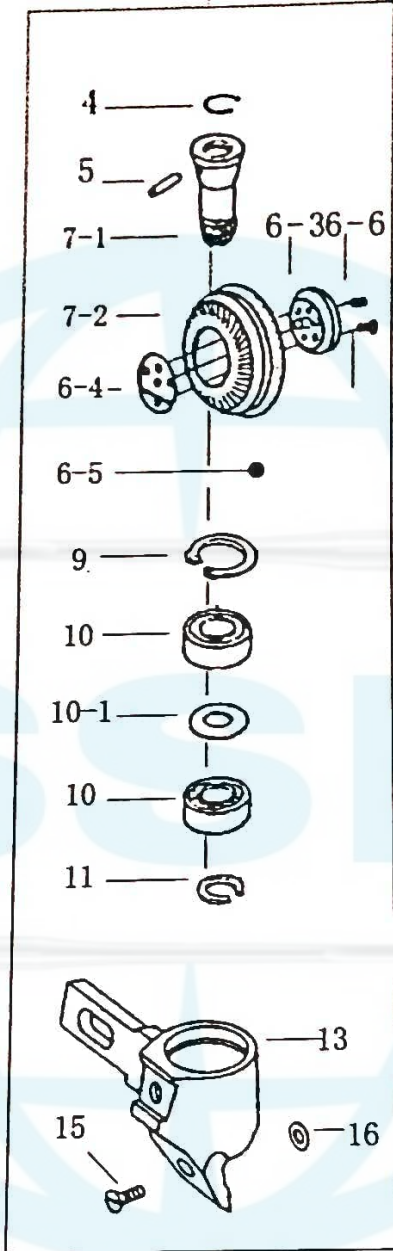

3 (Small)

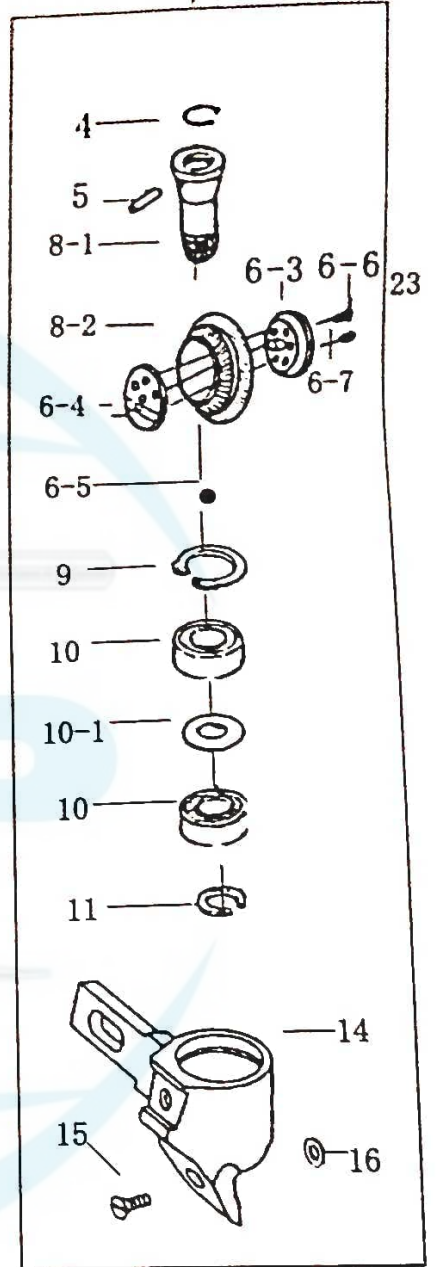

17

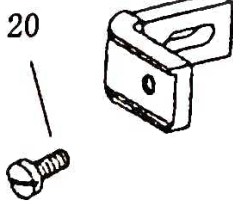

18

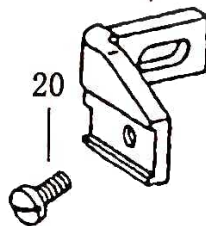

19

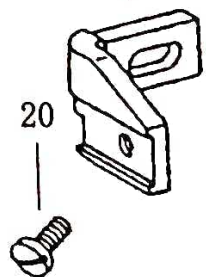



ROLLER PRESSER FOOT MECHANISM FOR 9910,9920

輪錢組機構

Ref.No	Part No.	Name of Part	Amt.req.		Remarks	
			9910	9920		
1	119803	Roller Presser Assy.(large)	輪錢組 (大)	1	1	
2	119803-1	Roller Presser Assy.(Middle)	輪錢組 (中)	1	1	
3	119802	Roller Presser Assy.(Small)	輪錢組 (小)	1	1	
4	119469	Spring Washer	止輪環	1	1	
5	033145	Pin	平行梢	1	1	
6	175109	Gear	齒輪	1	1	
6-1	175109-1	Gear Presser Shaft	傳動軸	1	1	
6-2	175109-2	Gear	齒輪盤	1	1	
6-3	175109-3	Gear Presser Shaft Seat(Front)	輪錢軸座 (前)	1	1	
6-4	175109-4	Gear Presser Shaft Seat	輪錢軸座 (後)	1	1	
6-5	175109-5	Ball	鋼珠	1	1	
6-6	175109-6	Screw	螺絲	1	1	
6-7	175109-7	Screw	螺絲	1	1	
7	175107	Gear	齒輪	1	1	
7-1	175107-1	Gear Presser Shaft	傳動軸	1	1	
7-2	175107-2	Gear	齒輪盤	1	1	
7-3	175107-3	Gear Presser Shaft Seat	輪錢軸座	1	1	
8	175108	Gear	齒輪	1	1	
8-1	175108-1	Gear Presser Shaft	傳動軸	1	1	
8-2	175108-2	Gear	齒輪盤	1	1	
8-3	175108-3	Gear Presser Shaft Seat	輪錢軸座	1	1	
9	664290	Retaining Ring	C型扣環	1	1	
10	133116	Ball Bearing	滾珠軸承	1	2	
10-1	133116-1	Washer	墊圈	1	1	
11	518210	Retaining Ring	C型扣環	1	1	
12	119953	Roller Presser Bracket	輪錢座	1	1	
13	119943	Roller Presser Bracket	輪錢座	1	1	
14	119956	Roller Presser Bracket	輪錢座	1	1	
15	210043	Screw	螺絲	1	1	
16	119491	Washer	墊圈	1	1	
17	119807	Guide Seat	輪錢連接座 (大)	1	1	
18	119955	Guide Seat	輪錢連接座 (中)	1	1	
19	119954	Guide Seat	輪錢連接座 (小)	1	1	
20	173174	Screw	螺絲	2	1	

# THREAD TAKE-UP LEVER MECHANISM 天秤機構

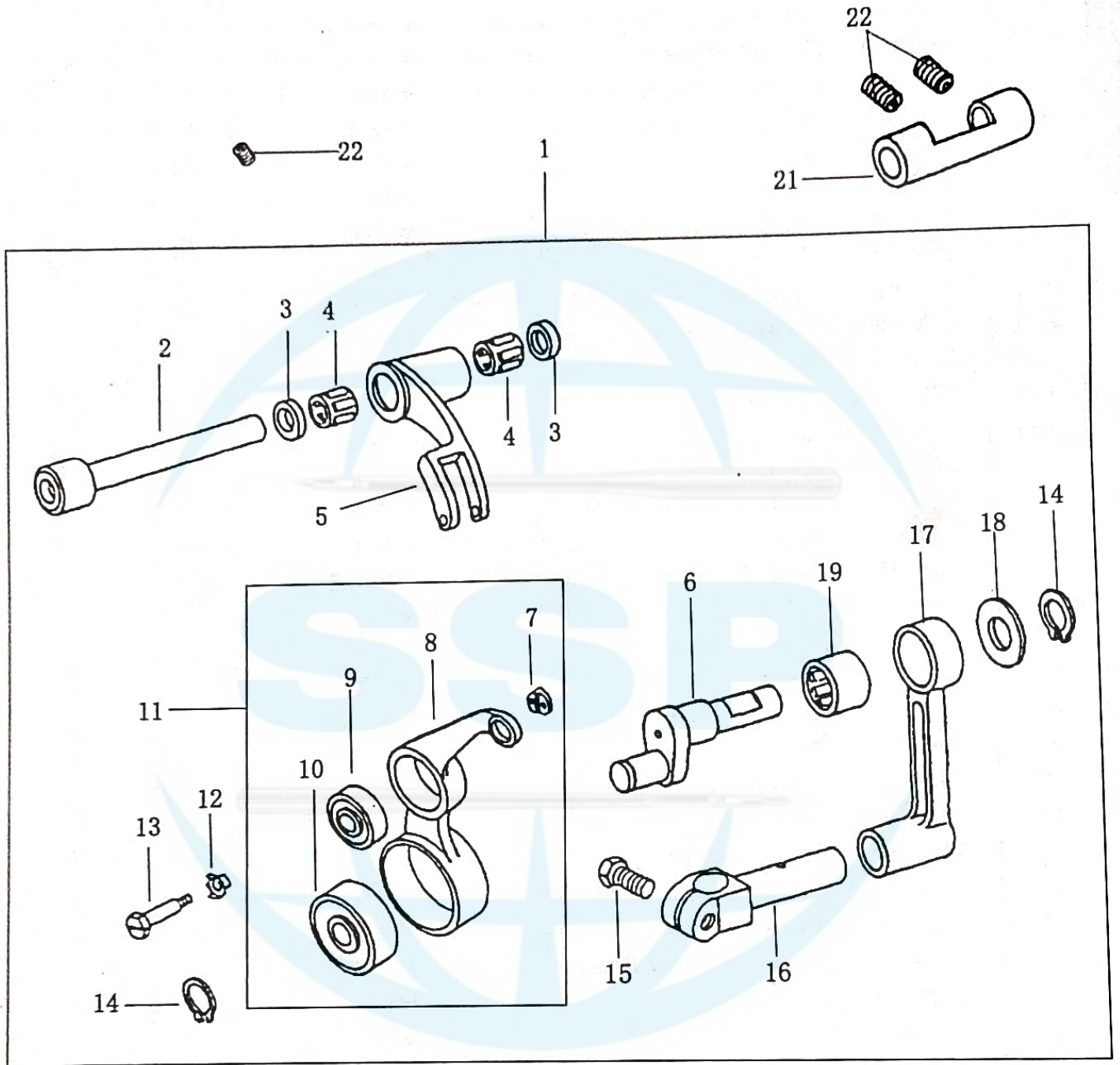

THREAD TAKE-UP LEVER MECHANISM  
 天秤機構

Ref.No	Part No.	Name of Part	Amt.req.		Remarks
			9910	9920	
1	118084	Thread Take-up Assy	1	1	(2~19)
2	119009	Take-up Lever Support Stud	1	1	
3	168039	Washer	2	2	
4	215022	Needle Bearing	2	2	
5	119008	Take-up Frame	1	1	
6	119762	Take-up Crank Pin	1	1	
7	119049	Bushing	1	1	
8	119007	Take-up Le er	1	1	
9	167569	Ball Bearing	1	1	
10	167570	Ball Bearing	1	1	
11	119006	Take-up Lever	1	1	(7~10)
12	168046	Washer	1	1	
13	168047	Screw	1	1	
14	610210	Retaining Ring	2	2	
15	039177	Screw	1	1	
16	119013	Needle Bar Connecting Stud	1	1	
17	119765	Needle Bar Connecting Crank Rod	1	1	
18	119763	Washer	1	1	
19	218080	Needle Bearing	1	1	
20	118518	Needle Bar Guide Slide Block	1	1	
21	168041	Bushing	1	1	
22	314220	Screw	3	3	



# UPPER SHAFT AND BALANCE WHEEL MECHANISM 上軸、皮帶輪機構

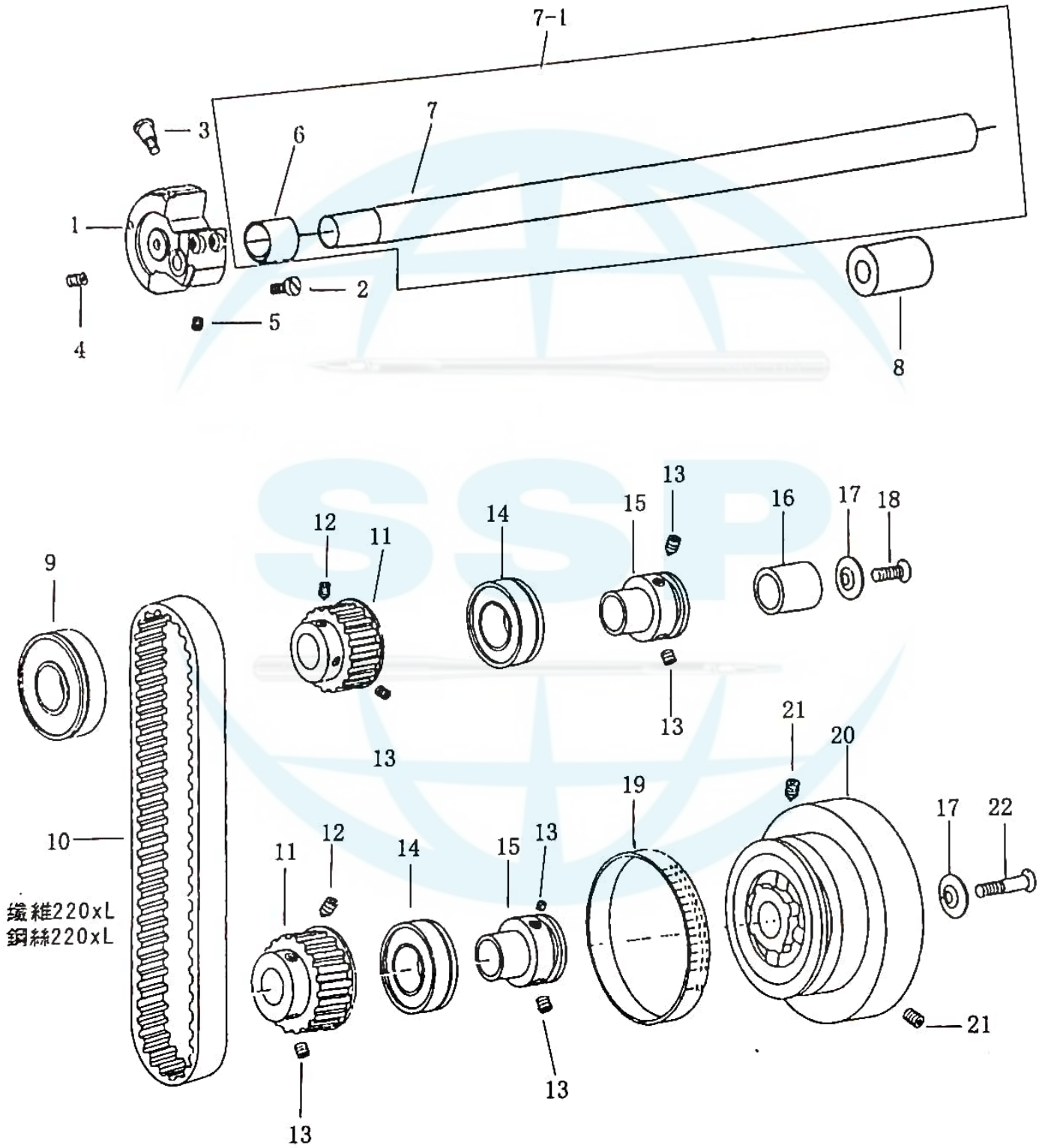

UPPER SHAFT AND BALANCE WHEEL MECHANISM  
上軸、皮帶輪機構

Ref.No	Part No.	Name of Part	Amt.req.		Remarks	
			9910	9920		
1	119702-2	Crank Cam	凸輪	1	1	
2	130224	Screw	螺絲	2	2	
3	119702-3	Screw	螺絲	1	1	
4	119702-4	Screw	螺絲	1	1	
5	700510	Screw	螺絲	1	1	
6	119702-5	Bushing	上軸套環	1	1	
7	119702-1	Upper Sh ft	上軸	1	1	
7-1	119702A	Upper Sh ft Assy	上軸套環組	1	1	
8	119702-6	Bushing	套環	0	1	
9	018643	Ball Bearing	滾珠培林	1	1	
10	069160	Timing Belt	皮帶	1	1	
10-1	169160-1	Timing Belt	皮帶	1	1	
11	119707	Timing Belt Wheel	齒形皮帶輪	2	2	
12	335902	Screw	螺絲	2	2	
13	335902-1	Screw	螺絲	6	6	
14	016153	Ball Bearing	滾珠培林	2	2	
15	119705	Upper Shaft Bushing	上軸套管	2	2	
16	069746	Bushing	上軸套管	1	1	
17	168480	Washer	華司	2	2	
18	210265	Screw	螺絲	1	1	
19	175048	Feed Regulator Scale	縫目指示環	1	1	
20	170913	Pulley Blance Wheel	皮帶輪	1	1	
21	341902	Screw	螺絲	2	2	
22	210287	Screw	螺絲	1	1	

UPPER SIDE SHAFT MECHANISM 9910,9920

上邊心機構

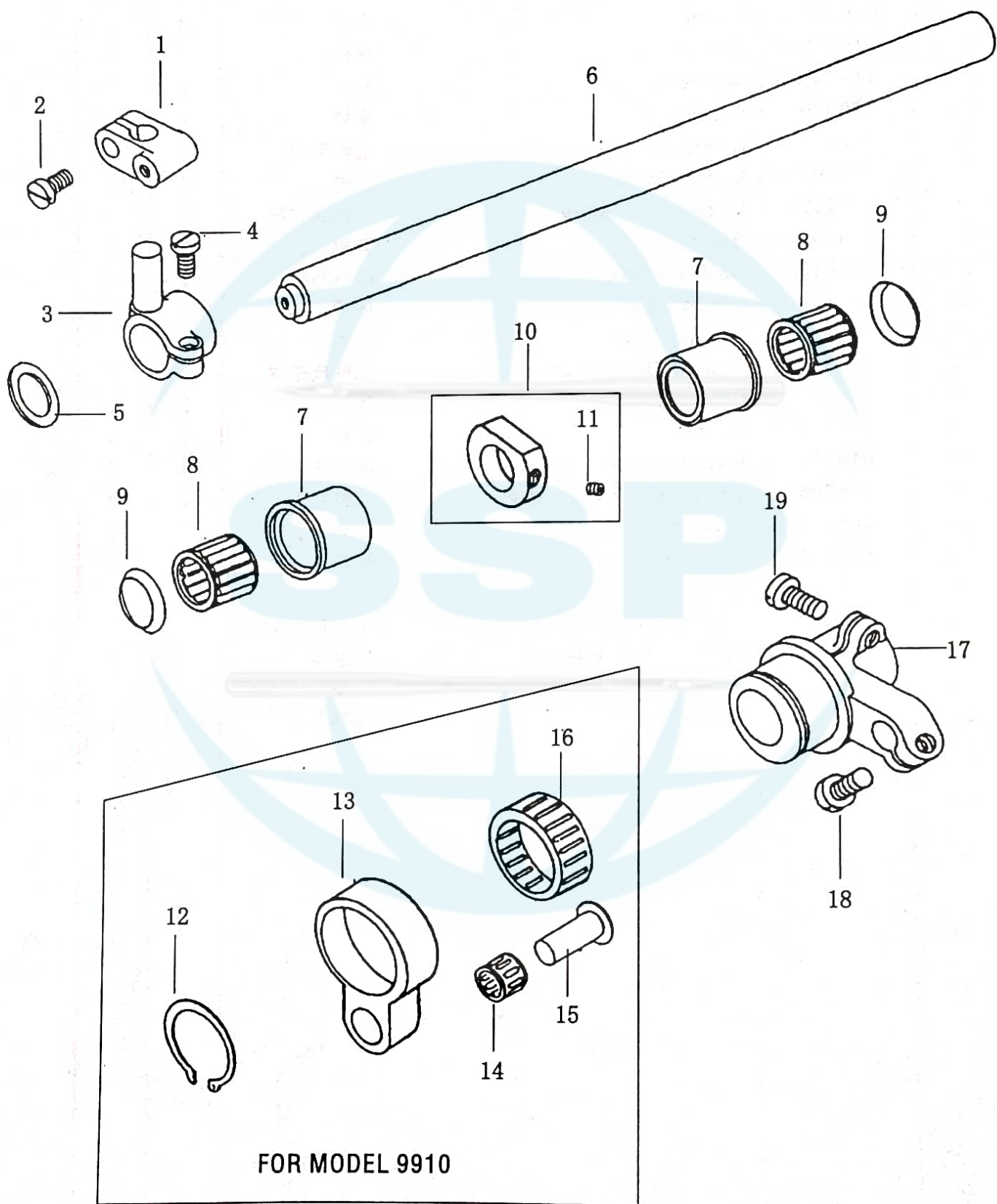



UPPER SIDE SHAFT MECHANISM  
上邊心機構

Ref.No	Part No.	Name of Part	Amt. req.		Remarks	
			9910	9920		
1	119164	Clamp	萬向連結座	1	1	
2	108177	Screw	螺絲	1	1	
3	119163	Crank	萬向連結頭	1	1	
4	108225	Screw	螺絲	1	1	
5	119085	Washer	華司	1	1	
6	119511	Upper Side Shaft	上邊軸	1	1	
7	118600	Bushing	針形軸承套管	2	2	
8	215124	Needle Bearing	針狀培林	2	2	
9	133283	Washer	華司	2	2	
10	118504	Collar	定環	1	1	(11)
11	118503	Screw	螺絲	1	1	
12	610370	Retaining ring	C型扣環	1	0	
13	119042-2	Eccentric With Rod	凸輪連桿	1	0	
14	215028	Needle Bearing	針狀培林	1	0	
15	175150	Pin	固定梢(短)	1	0	
16	242810	Needle Bearing	針狀培林	1	0	
17	119042	Crank With Eccentric	小凸輪	1	1	
18	108225-2	Screw	螺絲	1	1	
19	130224	Screw	螺絲	1	1	

# NEEDLE BAR MECHANISM 針構機構

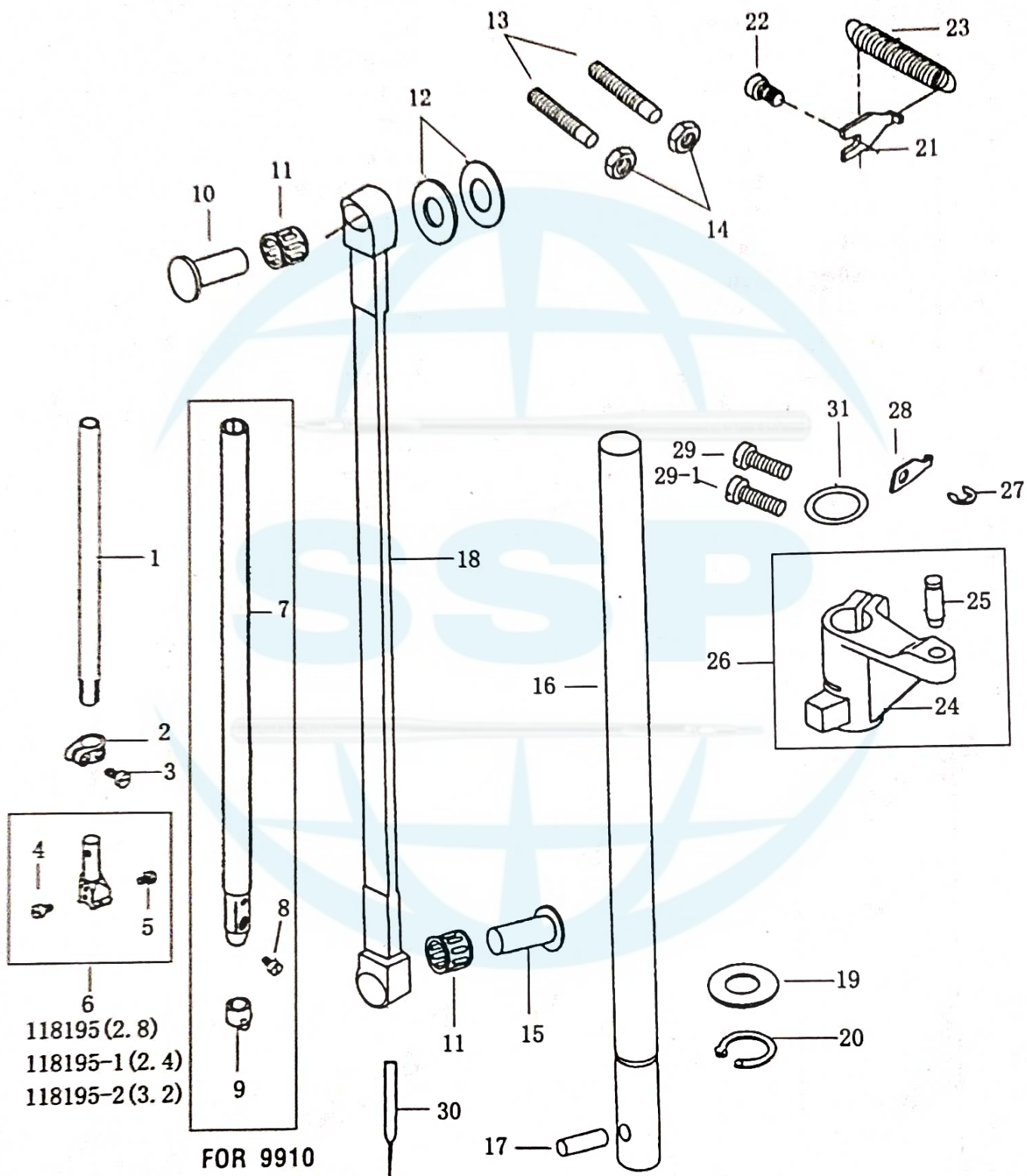

# NEEDLE BAR MECHANISM

## 針構機構

Ref.No	Part No.	Name of Part	Amt.req.		Remarks	
			9910	9920		
1	118197	Needle Bar	雙針針棒	0	1	
2	118196	Ring Clamp	針棒套環	0	1	
3	108174-1	Screw	螺絲	0	1	
4	700868	Screw	螺絲	0	1	
5	700868-1	Screw	螺絲	0	1	
6	118195	Needle Holder(2.8)	針榴	0	1	(4, 5)
	118195-1	Needle Holder(2.4)	針榴	0	1	(4, 5)
	118195-2	Needle Holder(3.2)	針榴	0	1	
7	175096	Needle Bar	單針針棒	1	0	
8	174173	Screw	螺絲	1	0	
9	175096-2	Thread Guide	針棒束環	1	0	
10	175150	Pin	固定梢(短)	1	1	
11	215028	Needle Bearing	針狀培林	2	2	
12	169137	Washer	華司	2	2	
13	305305	Screw	螺絲	2	2	
14	024191	Nut	螺帽	2	2	
15	118612	Pin	固定梢(長)	1	1	
16	119718	Shaft	腳押長軸	1	1	
17	030310	Pin	平行梢	1	1	
18	119046	Connecting Rod	連桿	1	1	
19	119525-2	Washer	華司	1	1	
20	119718-2	Retaining Ring	C型扣環	1	1	
21	118858	Spring Plate	彈簧固定板	1	1	
22	108285	Screw	螺絲	1	1	
23	118857	Spring	彈簧	1	1	
24	118543	Crank	上下輪送臂	1	1	
25	118544	Pin	彈簧固定梢	1	1	(24, 25)
26	118543A	Crank Shaft	腳押連杆上下臂	1	1	
27	640150	E-Ring	E型扣環	1	1	
28	020490	Spring Plate	彈簧勾板	1	1	
29	130224	Screw	螺絲	2	2	
29-1	130224-1	Screw	螺絲	1	1	
30	134356	Needle	針	1	1	
31	118545	Washer	華司	1	1	



# NEEDLE BAR FEED MECHANISM 針棒進給機構

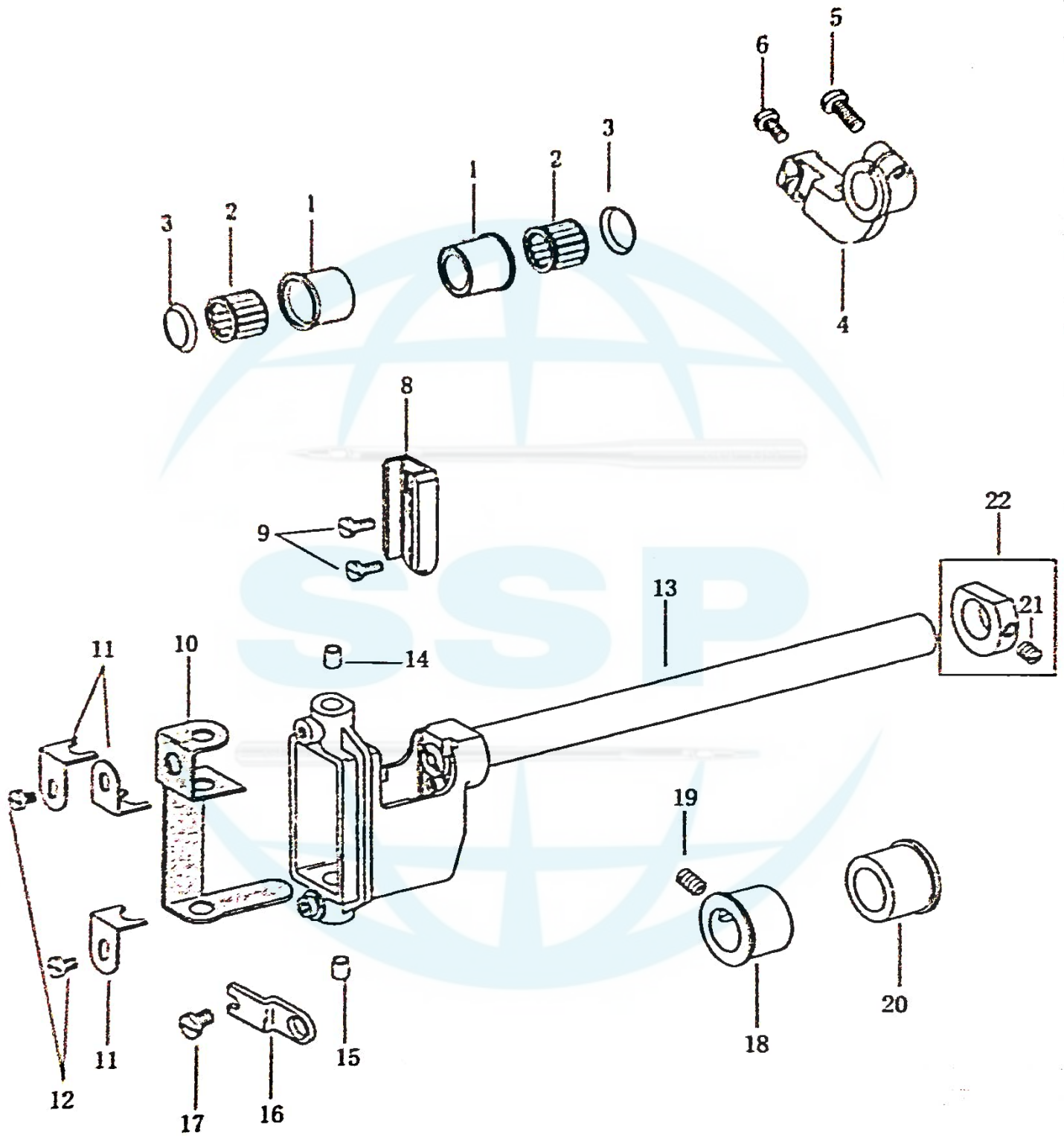

# NEEDLE BAR FEED MECHANISM

## 針棒進給機構

Ref.No	Part No.	Name of Part		Amt.req.		Remarks
				9910	9920	
1	118600	Bushing	套管	2	0	
2	215124	Needle Bearing	針狀培林	2	0	
3	133283	Washer	華司	4	0	
4	118610	Crank	針送支臂	1	0	
5	108285-1	Screw	螺絲	1	0	
6	130224	Screw	螺絲	1	0	
8	118594	Needle Bar Connecting Link Guide	針棒連接器導槽	1	1	
9	100355	Screw	螺絲	2	2	
10	119014	Oil Felt	油棉	1	1	
11	119015	Holder	油棉壓板	3	3	
12	706169	Screw	螺絲	2	2	
13	119940	Needle Bar Holder	針棒支持座	1	1	
14	119940-5	Needle Bar Bushing	針棒套管(上)	1	1	
15	119940-4	Needle Bar Bushing	針棒套管(下)	1	1	
16	118521	Needle Bar Support Frame Retainer	針棒固定板	0	1	
17	108219	Screw	螺絲	0	1	
18	118520	Bushing	套管	0	1	
19	314286	Screw	螺絲	0	1	
20	118520-1	Bushing	套管	0	1	
21	118503	Screw	螺絲	1	1	
22	118504	Collar	定環	1	1	(21)

# PRESSER FOOT BAR MECHANISM

## 押棒機構

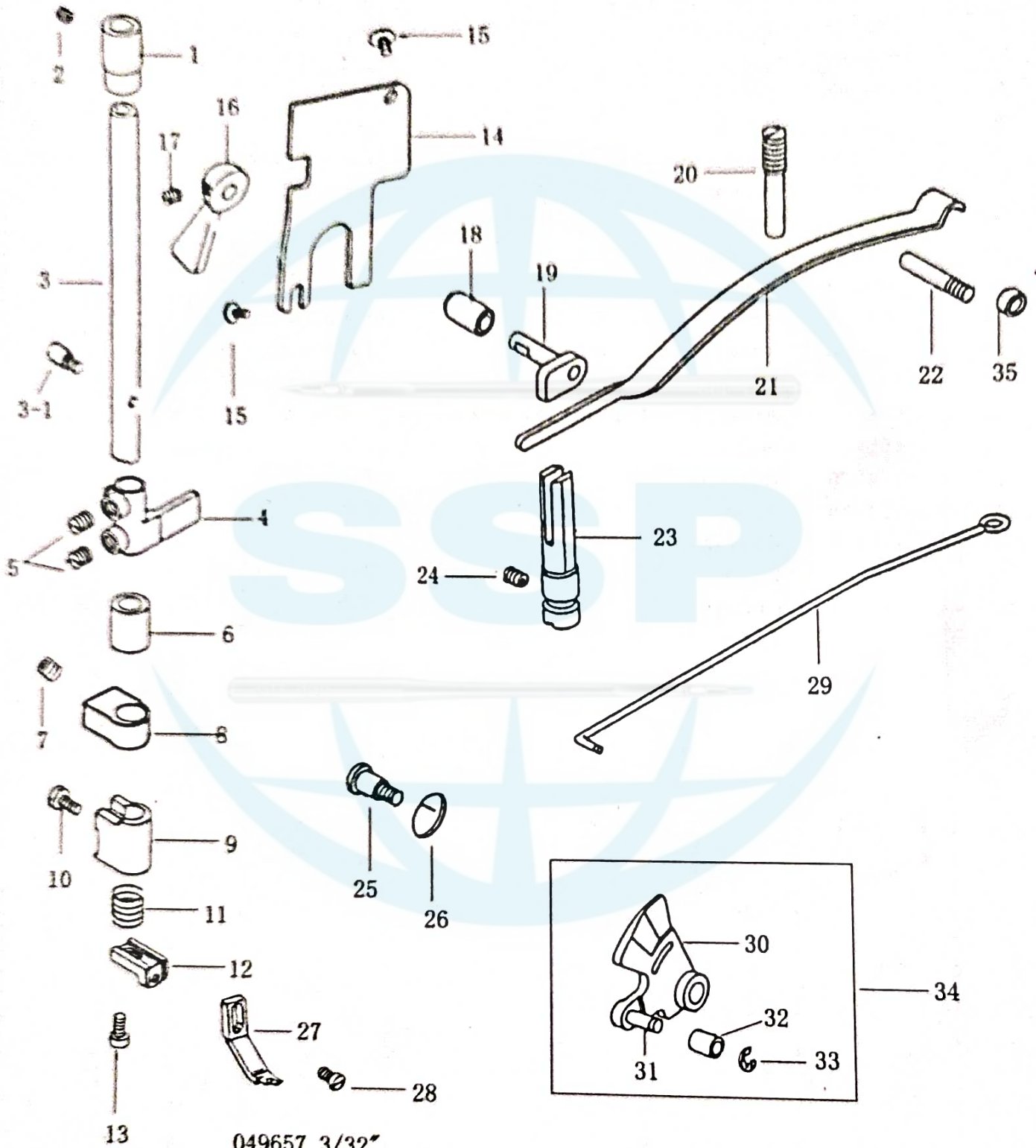

049657 3/32"  
049657-1 1/16"



PRESSER FOOT BAR MECHANISM  
 押棒機構

Ref.No	Part No.	Name of Part	Amt.req.		Remarks	
			9910	9920		
1	119019	Presser Bar Bushing(Upper)	押棒套管 (上)	1	1	
2	700785	Screw	螺絲	1	1	
3	119018	Presser Bar	押棒	1	1	
3-1	119018-1	Pin	梢子	1	1	
4	118530	Presser Bar Holder	壓棒固定座	1	1	
5	700510	Screw	螺絲	2	2	
6	119019-1	Presser Far Bushing(Lower)	押棒套管 (下)	1	1	
7	700510-1	Screw	螺絲	1	1	
8	119165-1	Roller Presser Holder	輪錢上座	1	1	
9	119165	Roller Presser Holder	輪錢下座	1	1	
10	173174	Screw	螺絲	1	1	
11	025874	Spring	彈簧	1	1	
12	054876	Angle	頂針座	1	1	
13	130173	Screw	螺絲	1	1	
14	175135	Cover	小防砂板	1	1	
15	700335	Screw	螺絲	2	2	
16	069079	Presser Foot Lifter	押棒提桿	1	1	
17	317950	Screw	螺絲	1	1	
18	119004	Bushing	押棒提桿套管	1	1	
19	118577	Cam Shaft	押棒提桿軸	1	1	
20	100331	Screw	螺絲	1	1	
21	118535	Presser Plate Spring	彈片壓板	1	1	
22	343901	Screw	螺絲	1	1	
23	118105	Stud	軌導棒	1	1	
24	314286	Screw	螺絲	1	1	
25	700017	Screw	螺絲	1	1	
26	119016	Spring	彈簧	1	1	
27	049657	Ptesser Foot	押腳	0	1	
	049657-1	Ptesser Foot	押腳	0	1	
28	108171	Screw	螺絲	0	1	
29	118542	Knee Lifter Connecting Lever	腳弓連接槓桿	1	1	
30	118536	Spring Plate	押上板	1	1	
31	118536-1	Pin	梢子	1	1	
32	118539	Bushing	套管	1	1	
33	640150	E-Ring	E型扣環	1	1	
34	118536A	Lifting Lever Assy	押上板組	1	1	
35	343902	Bushing	套環	1	1	(30~33)

TIMING BELT DRIVING MECHANISM FOR, 9910,9920  
皮帶傳動機構

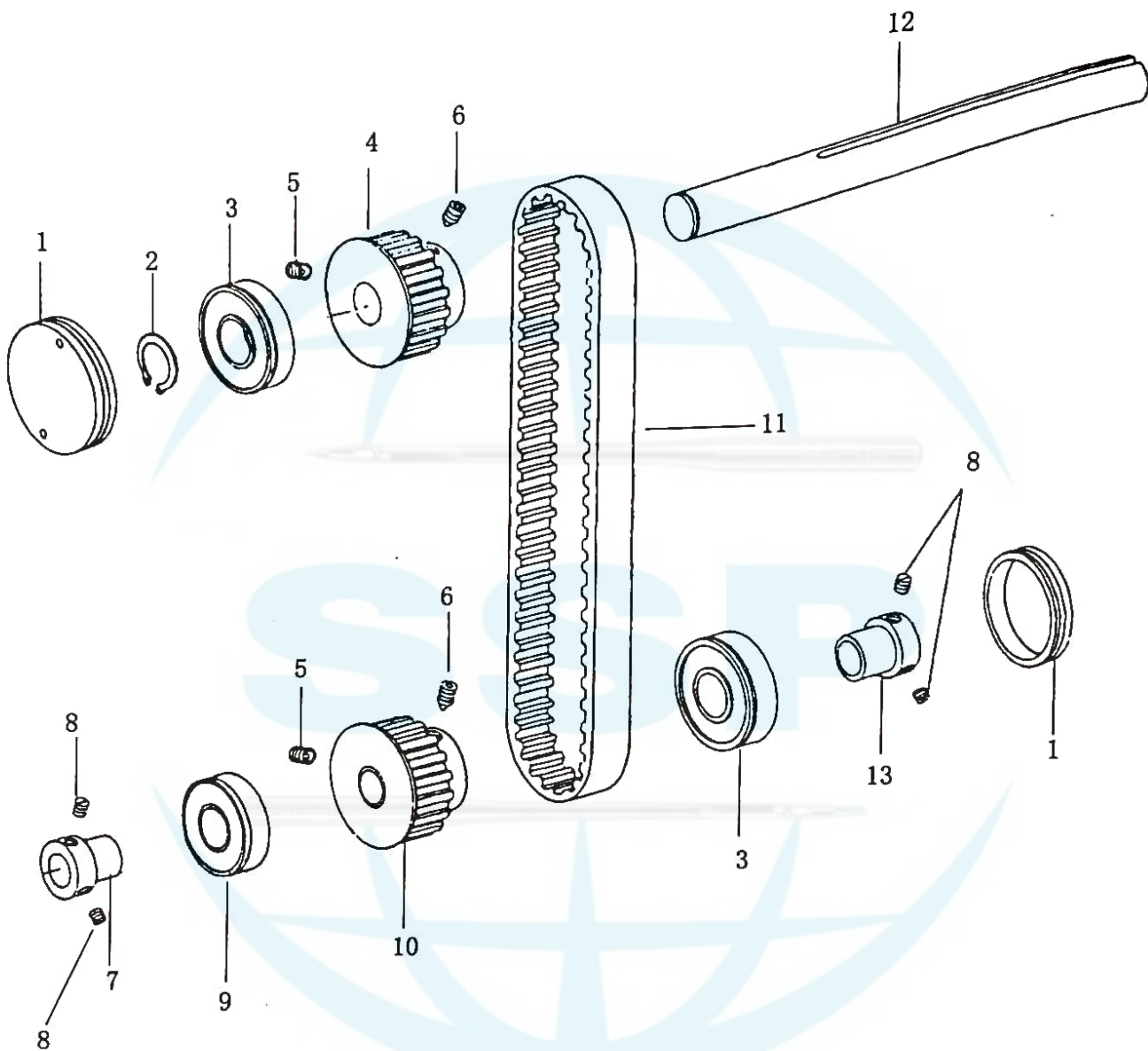

TIMING BELT DRIVING MECHANISM FOR, 9910,9920  
皮帶傳動機構

Ref.No	Part No.	Name of Part	Amt.req.		Remarks
			9910	9920	
1	119097	Plug 保護蓋	2	2	
2	610300	Retaining Ring C型扣環	1	1	
3	018624	Ball Bearing 滾珠軸承	2	2	
4	119707	Timing Belt Wheel 齒形皮帶輪	1	1	
5	335902-1	Screw 螺絲	2	2	
6	335902	Screw 螺絲	2	2	
7	119121	Collar(Left) 軸承套管(左)	1	1	
8	700689	Screw 螺絲	4	4	
9	018613	Ball Bearing 滾珠軸承	1	1	
10	119708	Timing Belt Wheel 齒形皮帶輪	1	1	
11	069161	Timing Belt 皮帶	1	1	
	069161-1	Timing Belt 皮帶	1	1	
12	119706	Shaft 皮帶輪軸	1	1	
13	118726	Collar(Right) 軸承套管(右)	1	1	



# STITCH ADJUSTER MECHANISM

## 縫目調整機構

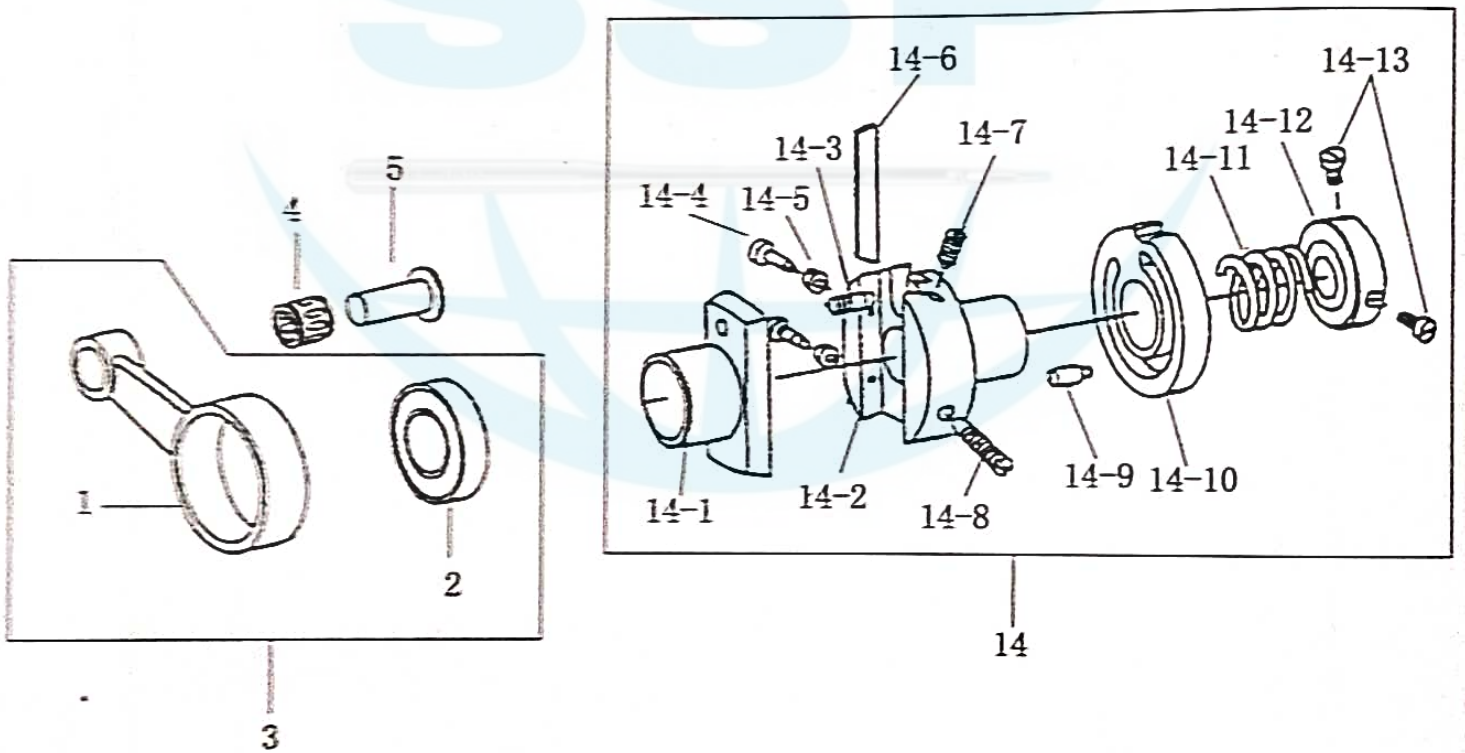
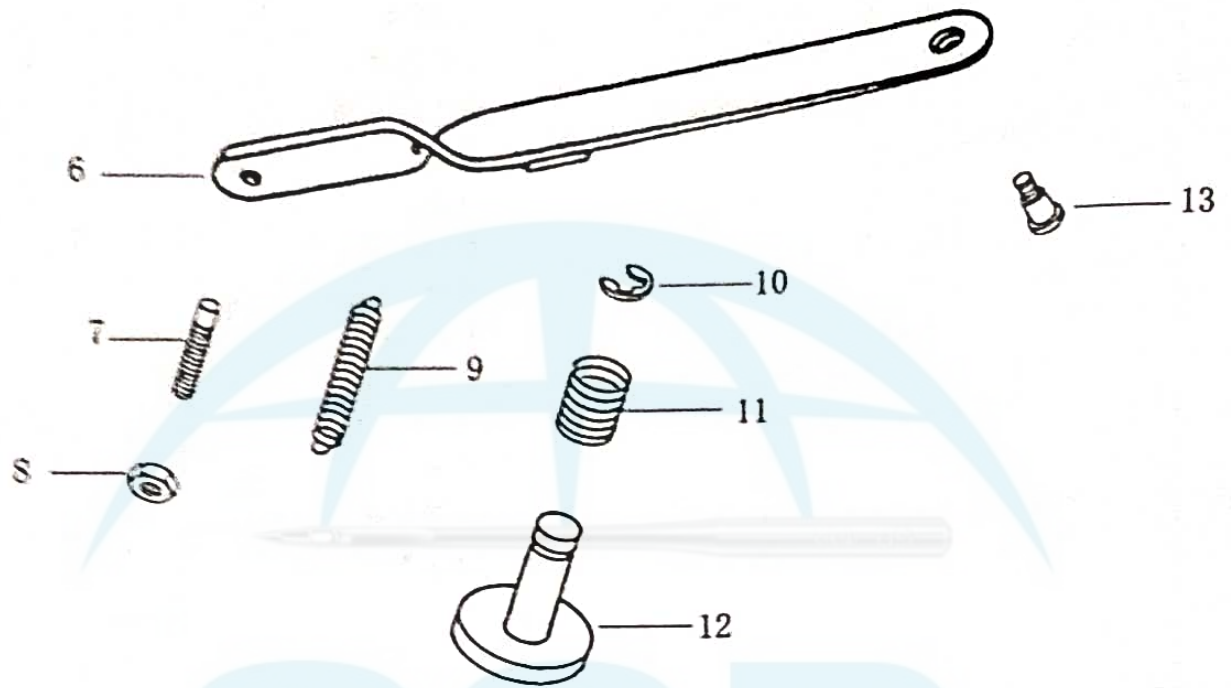

# STITCH ADJUSTER MECHANISM

## 縫目調整機構

Ref.No	Part No.	Name of Part	Amt.req.		Remarks
			9910	9920	
1	175038	Connecting Rod 連	1	1	
2	6906	Ball Bearing 滾珠軸承	1	1	
3	175038A	Crand Rod Set 毛毛連桿組	1	1	(1, 2)
4	215028	Needle Bearing 針狀軸承	1	1	
5	118612	Bearing Stud 固定銷(長)	1	1	
6	165356	Feeding Adjusting Plate 送料調節板	1	1	
7	165356-1	Screw 螺絲	1	1	
8	165356-8	Nut 螺帽	1	1	
9	165356-5	Spring 彈簧	1	1	
10	165356-7	E-ring E型扣環	1	1	
11	165356-6	Spring 彈簧	1	1	
12	165356-2	Pin 梢子	1	1	
13	165356-3	Screw 螺絲	1	1	
14	175029	Cam Assy 凸輪組	1	1	
14-1	175029-1	Stitch Regulating Sear 縫目調整座	1	1	
14-2	175029-2	Stitch Regulating Fix Seat 縫目調整固定座	1	1	
14-3	175029-3	Feed Adjusting Screw 偏心調整支軸	1	1	
14-4	175029-4	Screw 螺絲	1	1	
14-5	175029-5	Nut 螺帽	1	1	
14-6	175029-6	Friction Plate 迫緊片	1	1	
14-7	175029-7	Screw 螺絲	1	1	
14-8	175029-8	Screw 螺絲	1	1	
14-9	175029-9	Screw 螺絲	1	1	
14-10	175029-10	Eccentric Wheel 縫目調整偏心輪	1	1	
14-11	175029-11	Spring 彈簧	1	1	
14-12	175029-12	Collar 套環	1	1	
14-13	175029-13	Screw 螺絲	2	2	

# FEED SHAFT MECHANISM 輸送傳動機構

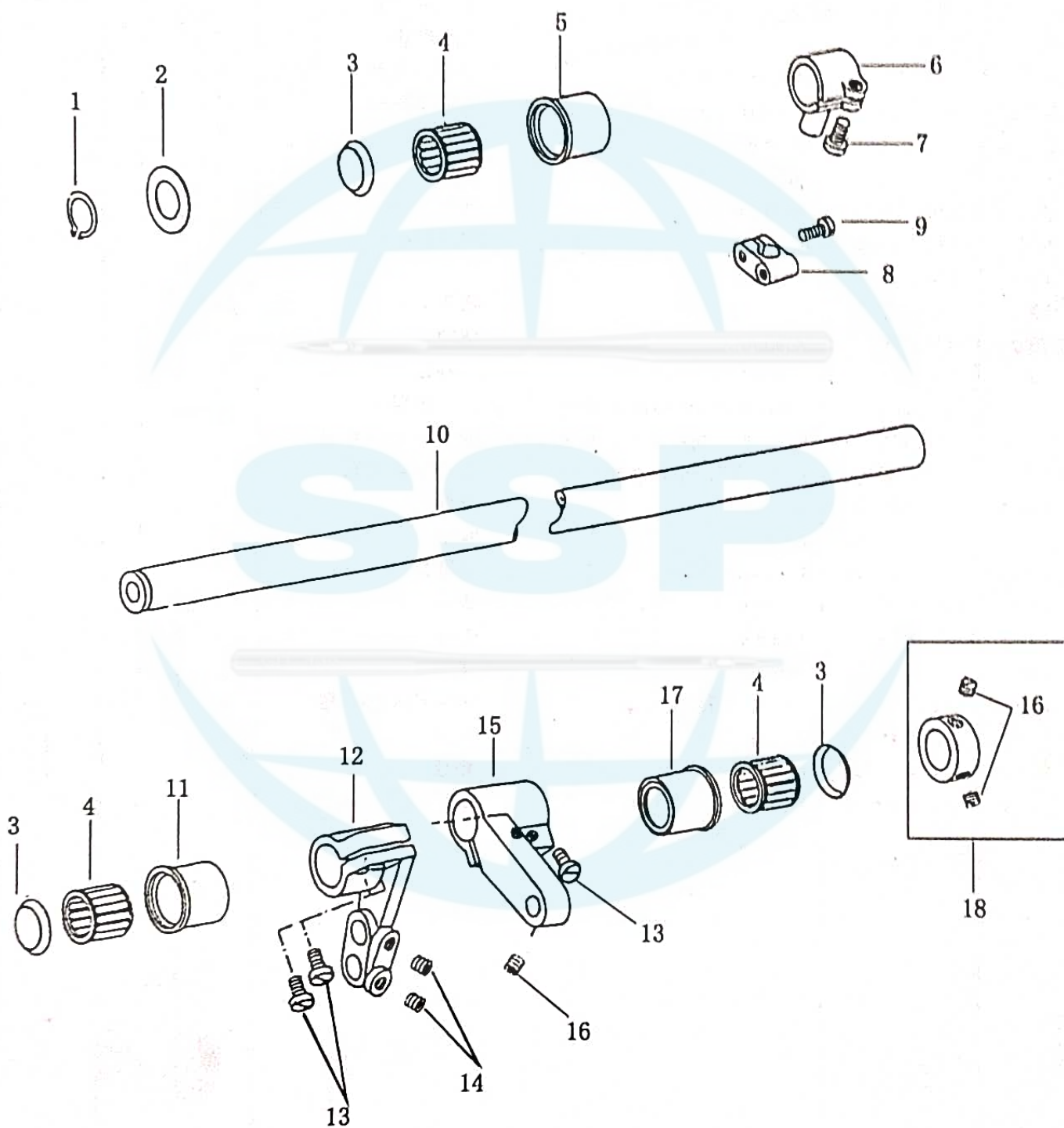



# FEED SHAFT MECHANISM

## 輸送傳動機構

Ref.No	Part No.	Name of Part	Amt.req.		Remarks
			9910	9920	
1	610280	Retaining Ring C型扣環	1	1	
2	119085	Washer 華司	1	1	
3	133283	Washer 針狀軸承蓋	6	6	
4	215124	Needle Bearing 針狀軸承	3	3	
5	118600	Bushing 套管	1	1	
6	119163	Crank 萬向連結頭	1	1	
7	108225	Screw 螺絲	1	1	
8	119164	Clamp 萬向連接座	1	1	
9	108177	Screw 螺絲	1	1	
10	119084	Shaft 輸送主軸	1	1	
11	118601	Bushing 套管	1	1	
12	119521	Crank 單向輸送支臂	1	1	
13	130224	Screw 螺絲	3	3	
14	335902-1	Screw 螺絲	2	2	
15	119521-1	Crank 單向輸送支臂	1	1	
16	700689	Screw 螺絲	3	3	
17	118603	Bushing 套管	1	1	
18	118893	Collar 上邊心定環	1	1	(16)

# CLUTCH SET MECHANISM 離合器機構

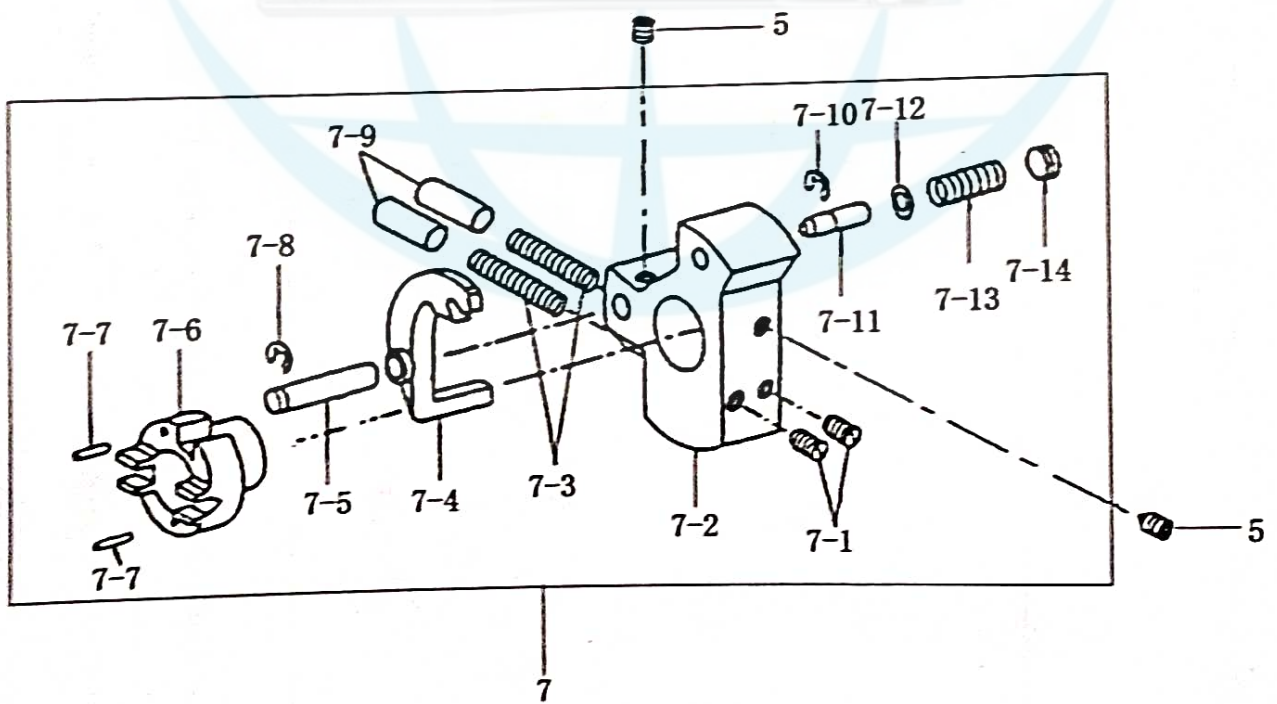
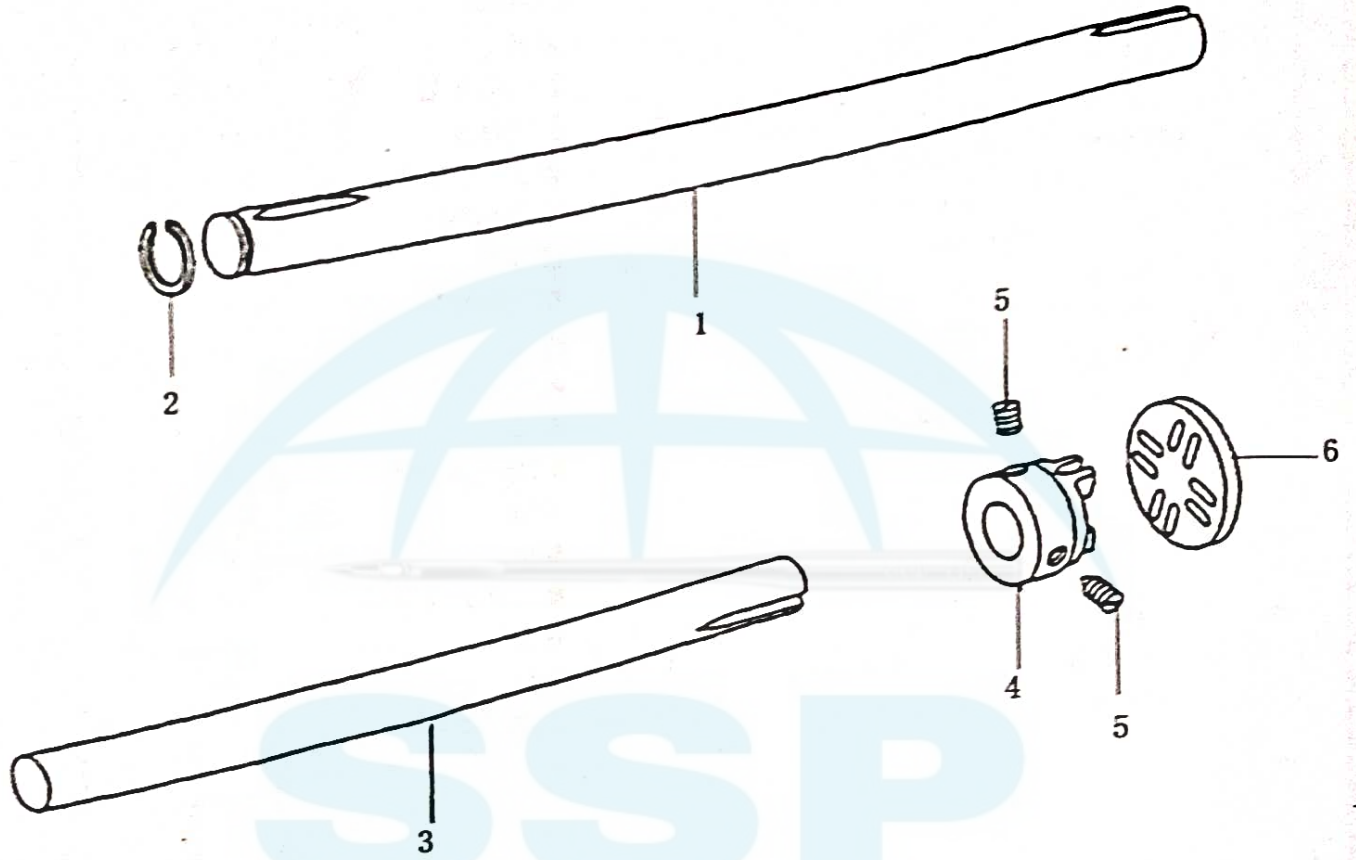

# CLUTCH SET MECHANISM

## 離合器機構

Ref.No	Part No.	Name of Part	Amt.req.		Remarks
			9910	9920	
1	175025	Shaft 萬向連結軸	1	1	
2	518250	Retaining Ring C型扣環	1	1	
3	119711	Shaft 萬向連結軸 (短)	1	1	
4	175019	Coupler 軸連器 (左)	1	1	
5	341901	Screw 螺絲	4	4	
6	133109	Connecting Plate 連接板	1	1	
7	119081A	Safety Clutch 離合器組	1	1	(7-1~7-14)
7-1	700510	Screw 螺絲	2	2	
7-2	173263	Safety Clutch Seat 離合器座	1	1	
7-3	013153	Spring 彈簧	2	2	
7-4	173261	Latch 離合器爪	1	1	
7-5	009408	Hinge Seud 固定座	1	1	
7-6	173264	Coupler(right) 軸連器 (右)	1	1	
7-7	065052	Pin 平行梢	2	2	
7-8	640150	E-Ring E型扣環	1	1	
7-9	175023	Stud 彈簧固定套	2	2	
7-10	640130	E-Ring E型扣環	1	1	
7-11	013076	Drop-In Pin 固定梢	1	1	
7-12	069037	Washer 華司	1	1	
7-13	009343	Spring 壓縮彈簧	1	1	
7-14	175126	Ring 固定螺絲	1	1	



BEDPLATE FEED MECHANISM FOR 9910  
單針中座機構

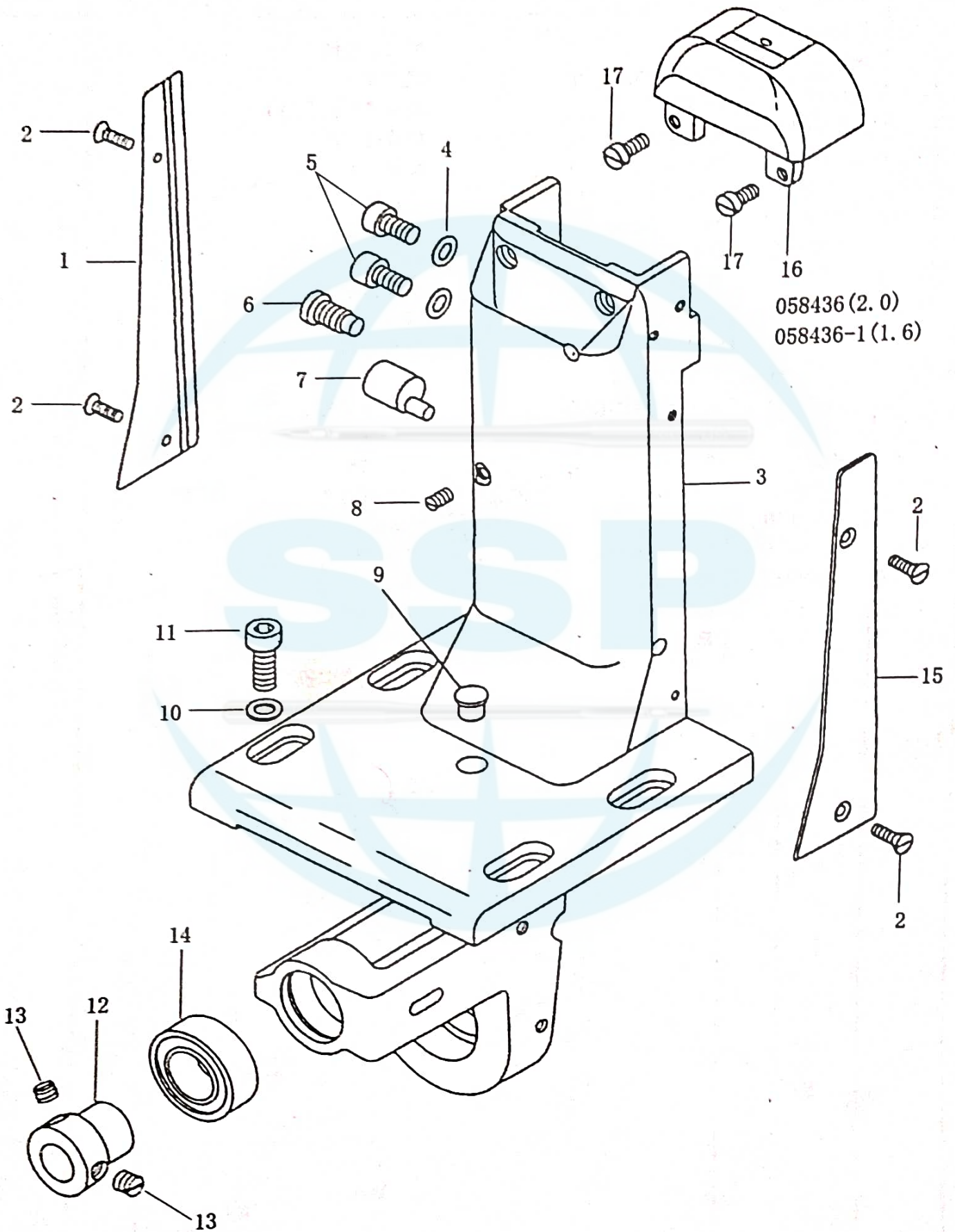

BEDPLATE FEED MECHANISM FOR 9910  
單針中座機構

Ref.No	Part No.	Name of Part	Amt.req.		Remarks
			9910	9920	
1	119145	Cover Plate 邊蓋板	1	0	
2	250084	Screw 螺絲	4	0	
3	119721	Support Plate 單針中座	1	0	
4	119144	Washer 華司	2	0	
5	130224	Screw 螺絲	2	0	
6	182451	Screw 螺絲	1	0	
7	119725	Stud 調整梢	1	0	
8	317170	Screw 螺絲	1	0	
9	168351	Plug 油蓋	1	0	
10	305174	Washer 華司	4	0	
11	135292	Screw 螺絲	4	0	
12	119121	Collar 主軸套管	1	0	
13	700689	Screw 螺絲	2	0	
14	016120	Ball Bearing 滾珠軸承	1	0	
15	305144	Cover Plate 邊蓋板	1	0	
16	058436	Needle Plate(2.0) 單針針板	1	0	
	058436-1	Needle Plate(1.6) 單針針板	1	0	
17	210168	Screw 螺絲	2	0	

BEDPLATE GEAR FEED MECHANISM FOR 9910  
 中座齒輪傳動機構

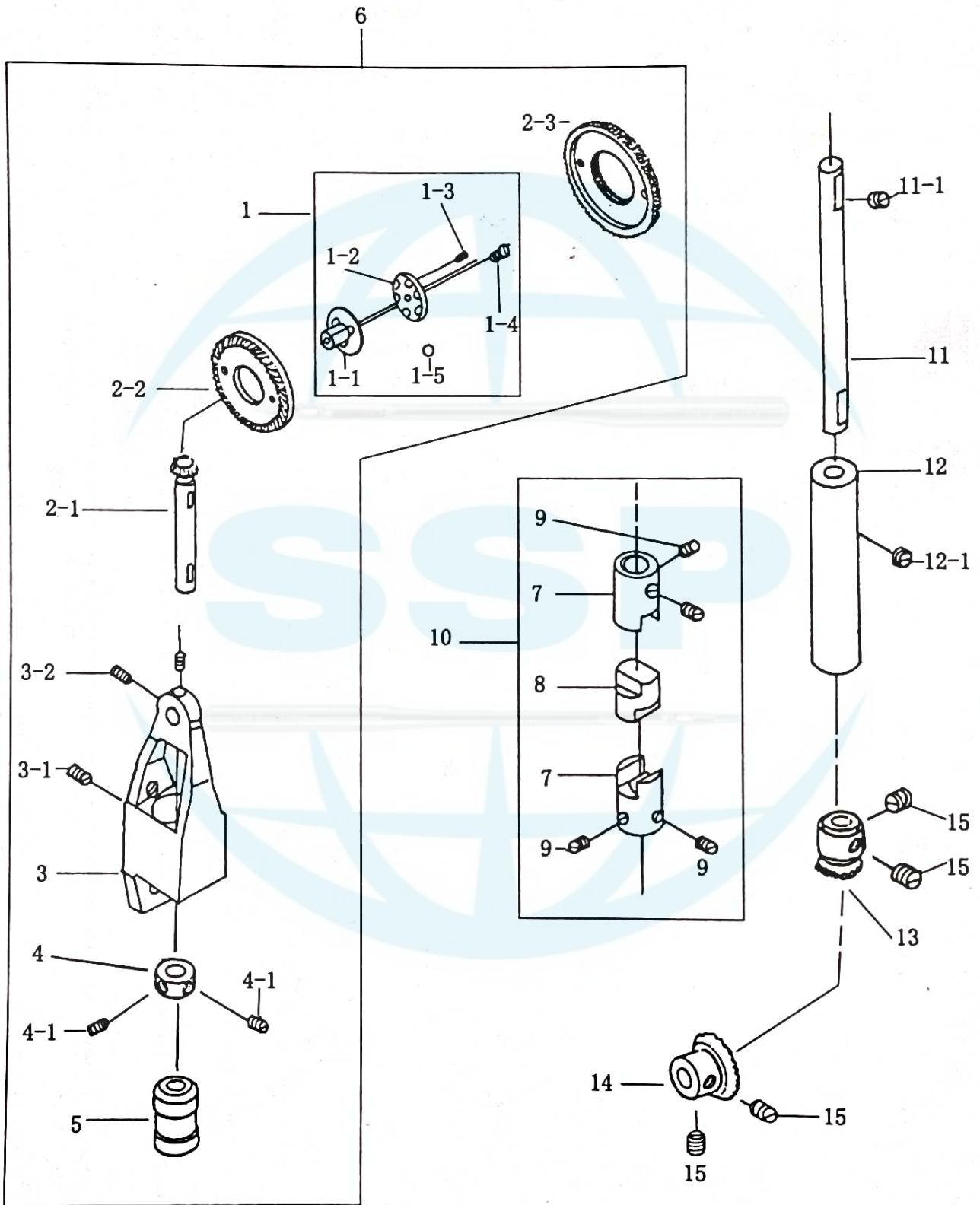



BEDPLATE GEAR FEED MECHANISM FOR 9910  
 中座齒輪傳動機構

Ref.No	Part No.	Name of Part	Amt. req.		Remarks	
			0010	0020		
1	119795	Roller Bracker	送料齒輪軸	1	0	
1-1	119795-1	Roller Bracker(Upper)	送料齒輪軸(上)	1	0	
1-2	119795-2	Roller Bracker(Lower)	送料齒輪軸(下)	1	0	
1-3	119795-3	Screw	螺絲	1	0	
1-4	119795-4	Screw	螺絲	1	0	
1-5	119795-5	Ball	鋼珠	24	0	
2	119737	Bevel Gear	上下送料齒輪	1	0	
2-1	119737-1	Roller Bracker	送料齒輪軸	1	0	
2-2	119737-2	Roller Bracker	送料大齒輪	1	0	
2-3	119737-3	Feed Wheel	送料輪	1	0	
3	119723	Bracket	送料齒輪座	1	0	
3-1	119723-1	Screw	螺絲	1	0	
3-2	119723-2	Screw	螺絲	2	0	
4	119670	Collar	定環	1	0	
4-1	119670-1	Screw	螺絲	2	0	
5	119724	Bushing	送料齒輪套環	1	0	(1-5)
6	119723A	Bevel Gear Assy	送料齒輪組	1	0	
7	119535	Bushing	軸連接器	2	0	
8	119534	Clutch	塑膠接頭	1	0	
9	119535-1	Screw	螺絲	4	0	(7-9)
10	119535A		連杆接頭組	1	0	
11	119532	Shaft	中座軸	1	0	
11-1	119535-1	Screw	螺絲	2	0	
12	119533		套管	1	0	
13	5045	Bushing	中座齒輪(小)	1	0	
14	5046	Bevel Gear(Small)	中座齒輪(中)	1	0	
15	700689	Bevel Gear(Medium)	螺絲	4	0	(13-15)
16	175113	Screw	中座齒輪組	1	0	

LEFT AND MIDDLE FEED MECHANISM FOR 9920  
左邊座和中座傳動機構

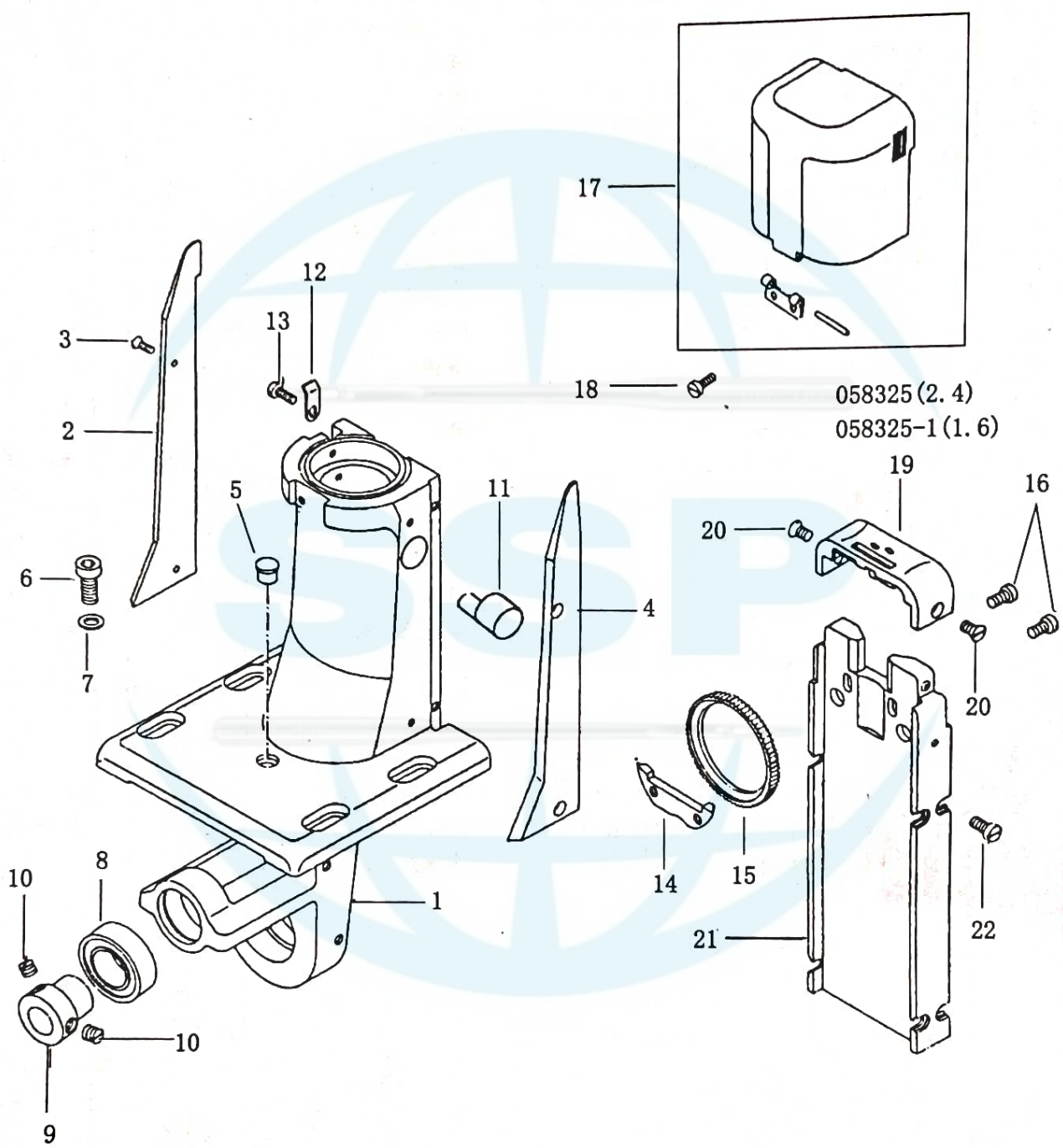

LEFT AND MIDDLE FEED MECHANISM FOR 9920  
 左邊座和中座傳動機構

Ref.No	Part No.	Name of Part		Amt.req.		Remarks
				9910	9920	
1	119976	Side Bracket(Left)	附耳邊座(左)	0	1	
2	119499	Cover Plate	邊蓋板	0	1	
3	250084	Screw	螺絲	0	4	
4	119695	Cover Plate	邊蓋板	0	1	
5	168351	Plug	油蓋	0	1	
6	135292	Screw	螺絲	0	4	
7	305174	Washer	橢圓華司	0	4	
8	016120	Ball Bearing	滾珠軸承	0	1	
9	119121	Collar	主軸套管	0	1	
10	700689	Screw	螺絲	0	2	
11	175318	Stud	調整梢	0	1	
12	119143	Spring Plate	彈簧板	0	1	
13	108093	Screw	螺絲	0	1	
14	119138	Bearing Plate	固定板	0	1	
15	119136	Feed Wheel	送料齒輪	0	1	
16	108174-1	Screw	螺絲	0	2	
17	119140	Post Cap Assy	釜蓋	0	2	
18	108093	Screw	螺絲	0	2	
19	058325	Needle Plate(2.4)	雙針針板	0	1	
	058325-1	Needle Plate(1.6)	雙針針板	0	1	
	058325-2	Needle Plate(2.0)	雙針針板	0	1	
20	100296	Screw	螺絲	0	2	
21	119296	Support Plate	雙針中座	0	1	
22	108174-1	Screw	螺絲	0	8	



LEFT BEDPLATE FEED MECHANISM FOR 9920  
左邊座傳動機構

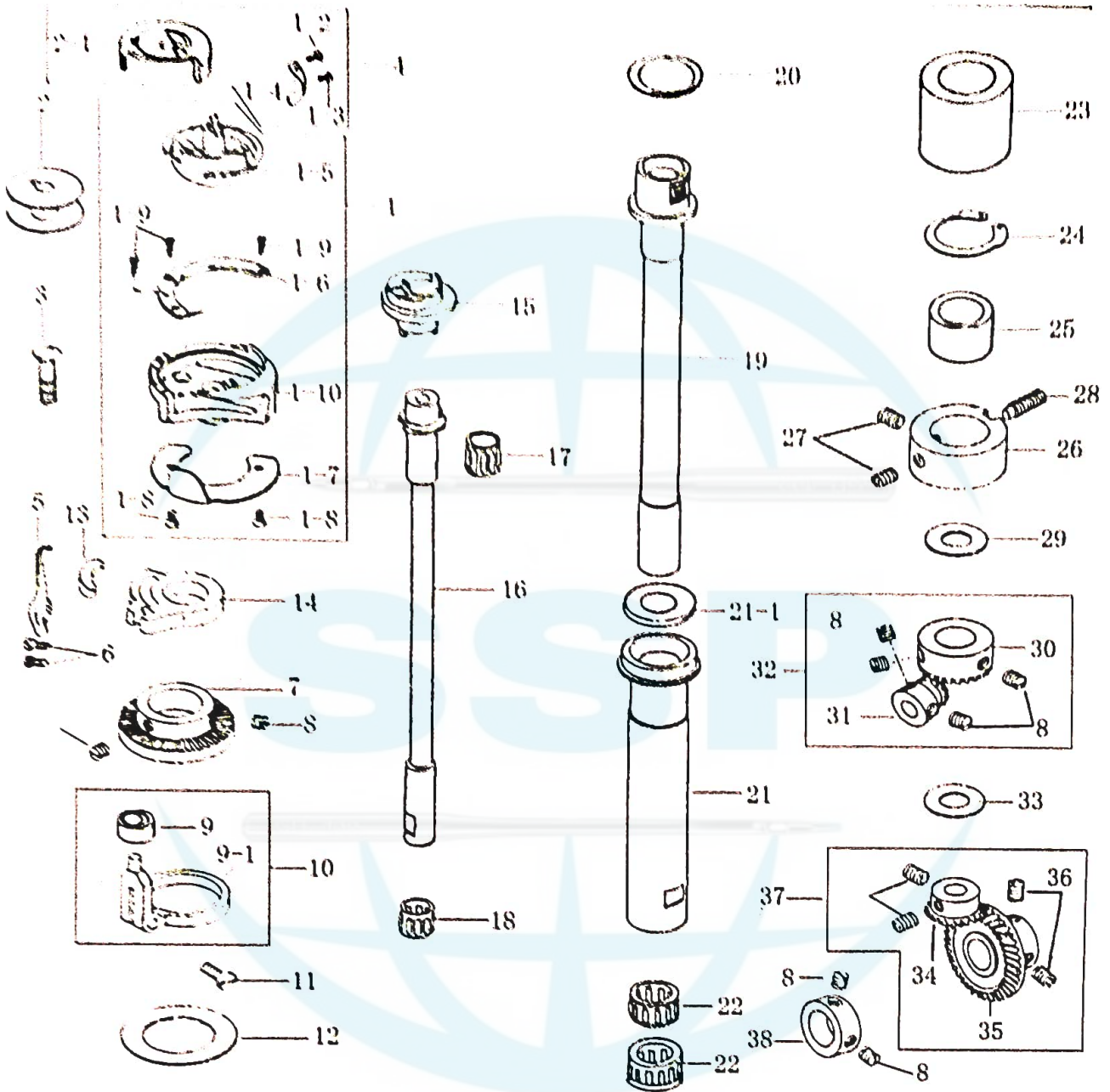

Ref. No	Part NO	Name of Part	Amt. req.		Remarks
			9910	9920	
1	119716A	Hook Assy	0	1	1-1~10
1-2	000390	Screw	0	1	
1-3	000928	Screw	0	1	
1-4	010166	Spring	0	1	
1-5	119487	B/C Base	0	1	
1-6	175136	Hook gib	0	1	
1-7	119377	Needle guard washer	0	1	
1-8	000219	Screw	0	2	

LEFT BEDPLATE FEED MECHANISM FOR 9920  
左邊座傳動機構

Ref.No	Part No.	Name of Part	Amt.req.		Remarks
			9910	9920	
1-9	100529	Screw	0	3	
1-10	119376	Hook	0	1	
2	010079	Bobbin	0	1	
2-1	010158	Bobbin Case	0	1	
3	100205	Screw	0	2	
4	119716	Bobbin Case Assy	0	1	
5	119129	Rotating Hook Opener	0	1	
6	108093	Screw	0	2	
7	119494	Driving Wheel	0	1	
8	700689	Screw	0	8	
9	69422	Ball Bearing	0	1	
9-1	119106-1	Driver	0	1	(9)
10	119106	Driver	0	1	
11	108177	Screw	0	1	
12	119105	Washer	0	1	
13	119128	Oilfelt	0	1	
14	119127	Rotating Hook Opener Bracket	0	1	
15	119525-1	Hook Driver	0	1	
16	119525	Hook Shaft	0	1	
17	215031	Needle Bearing	0	1	
18	215028	Needle Bearing	0	1	
19	119108	Feed Wheel Shaft	0	1	
20	125010	Washer	0	1	
21	119104	Pull-Off Shaft	0	1	
21-1	119108-1	Washer	0	1	
22	141710	Needle Bearing	0	2	
23	119979	Bushing	0	1	
24	664390	Retaining ring	0	1	
25	175138	Bushing	0	1	
26	119107	Bushing	0	1	
27	341901	Screw	0	2	
28	119950	Screw	0	1	
29	119947	Washer(0.2)	0	1	
29-1	119957	Washer(0.1)	0	2	
29-2	119958	Washer(0.15)	0	1	
29-3	119959	Washer(0.5)	0	1	
29-4	119960	Washer(2.0)	0	1	
30	119109-1	Bevel Gear(Large)	0	1	
31	119109-2	Bevel Gear(Small)	0	1	
32	119109	Bevel Gear Assy	0	1	(8,30,31)
33	125010	Washer(0.5)	0	2	
33-1	122718	Washer(0.1)	0	1	
33-2	125008	Washer(0.15)	0	1	
33-3	125009	Washer(0.2)	0	1	
34	119133-1	Bevel Gear(Small)	0	1	
35	119133-2	Bevel Gear(Large)	0	1	
36	341901-1	Screw	0	2	
37	119133	Gear Set	0	1	(8,34-36)
38	123778	Collar	0	1	

RIGHT SIDE BRACKET MECHANISM FOR 9910, 9920  
右邊座傳動機構

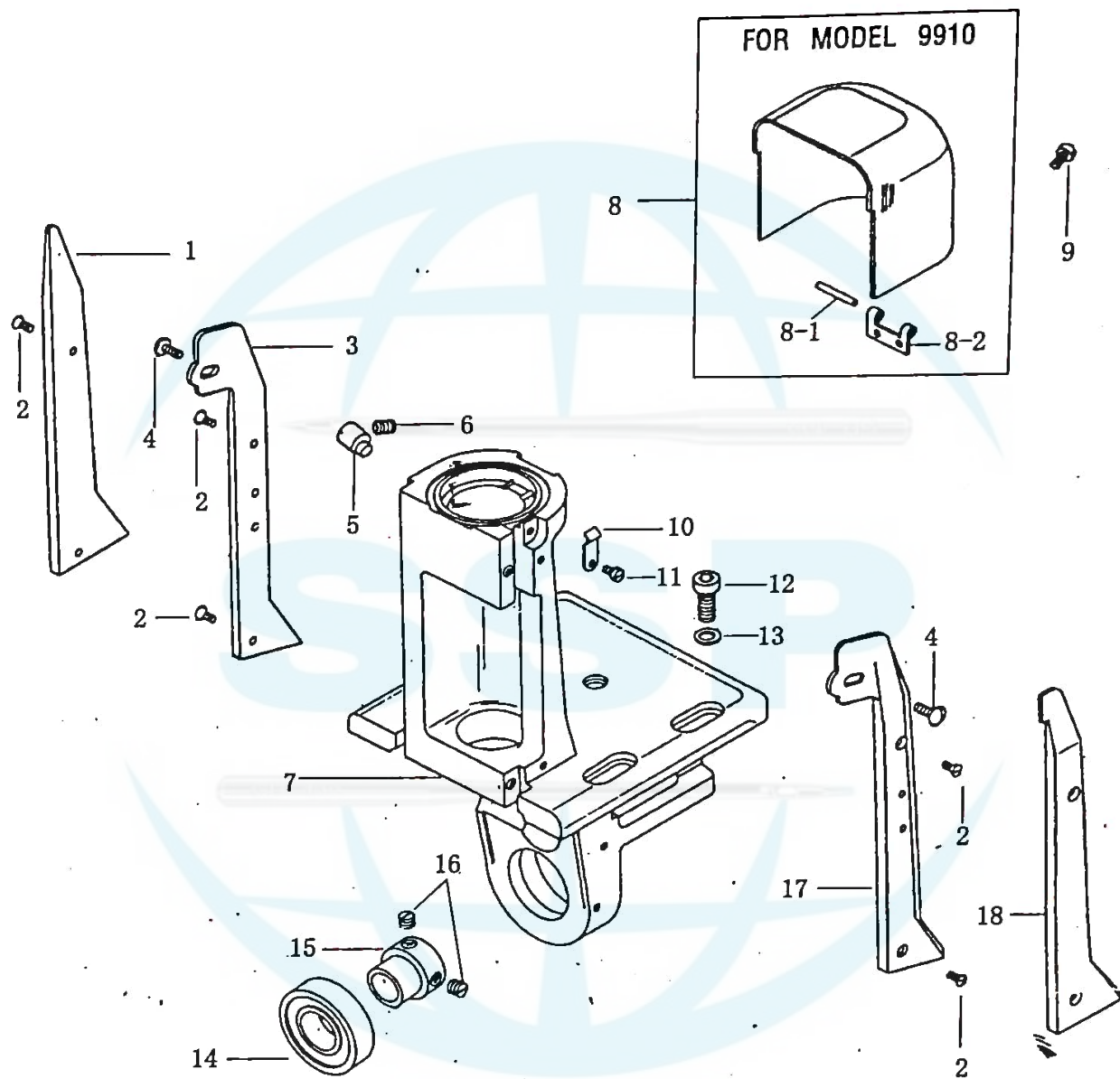



RIGHT SIDE BRACKET MECHANISM FOR 9910, 9920  
右邊座傳動機構

Ref.No	Part No.	Name of Part	Amt.req.		Remarks
			9910	9920	
1	119695	Cover Plate	0	1	
2	250084	Screw	4	4	
3	175267	Cover Plate	1	0	
4	700336	Screw	2	0	
5	175318	Stud	1	1	
6	330217	Screw	1	1	
7	175324	Side Bracket(Right)	1	0	
7-1	119168	Side Bracket(Right)	0	1	
8	119436	Post Cap Assy	1	0	
9	108093	Screw	2	0	
10	119143	Spring Plate	1	1	
11	108093	Screw	1	1	
12	135292	Screw	4	4	
13	305174	Washer	4	4	
14	016120	Ball Bearing	1	1	
15	119121	Collar	1	1	
16	700689	Screw	2	2	
17	175234	Cover Plate	1	0	
18	119499	Cover Plate	0	1	

FEED MECHANISM FOR 9910, 9920  
單向齒輪傳動機構

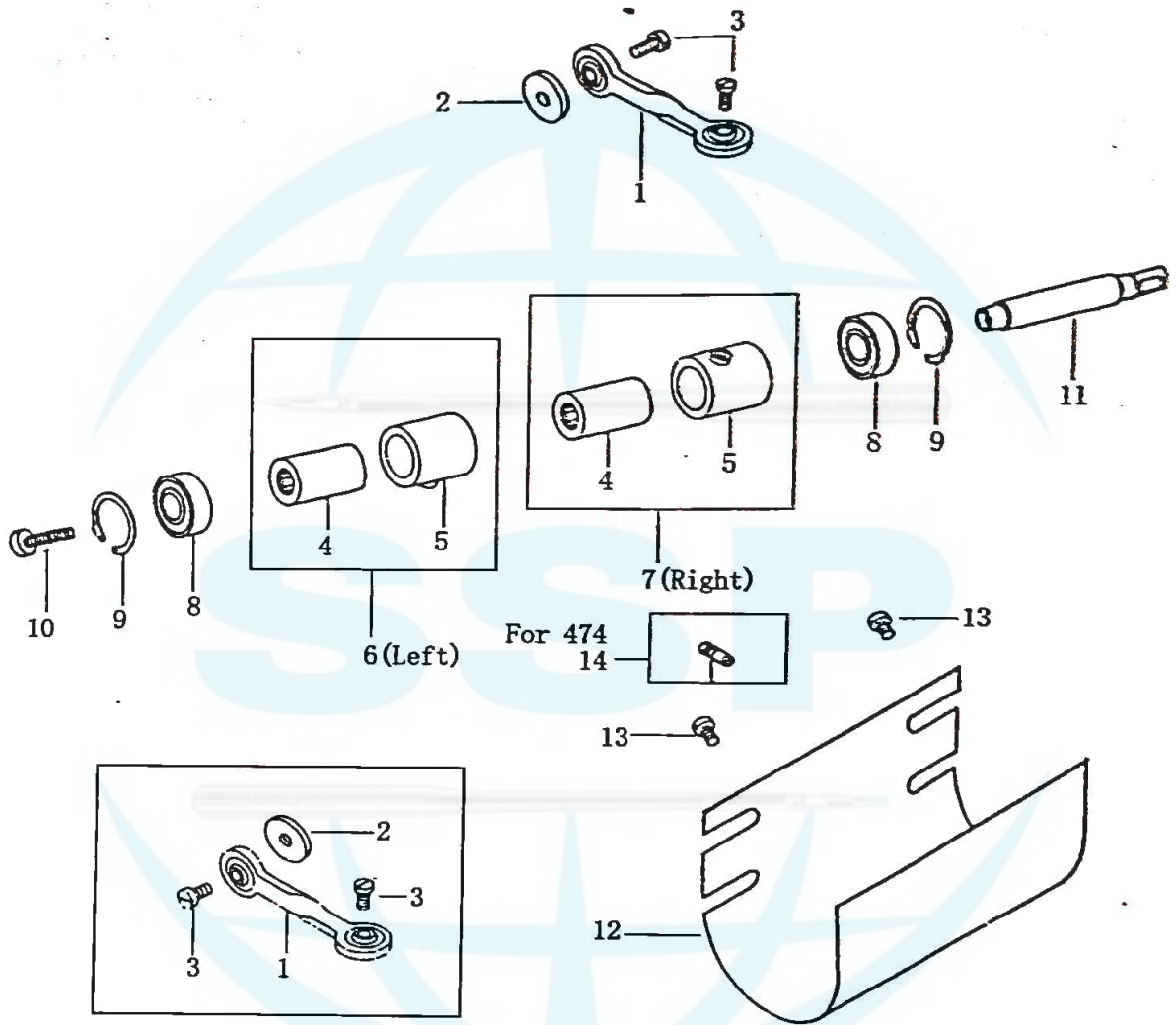

FEED MECHANISM FOR 9910, 9920  
單向齒輪傳動機構

Ref.No	Part No.	Name of Part	Amt.req.		Remarks
			9910	9920	
1	119507	Link 萬向軸承拉杆	2	1	
2	119087	Oil Felt 油棉	2	1	
3	174176	Screw 螺絲	4	2	
4	061014	Needle Bearing 針狀軸承	2	2	
5	119115-1	Free-Wheeling Seat 單向培林座	2	2	
6	119112	Free-Wheeling(left) 單向培林座組(左)	1	1	(4, 5)
7	119115	Free-Wheeling(Right) 單向培林座組(右)	1	1	(4, 5)
8	012555	Ball Bearing 滾珠軸承	2	2	
9	664350	Retaining Ring C型扣環	2	2	
10	173174	Screw 螺絲	1	1	
11	119111	Shaft 培林軸	1	1	
12	119216	Housing Front Section 護片	1	1	
13	108174	Screw 螺絲	4	4	
14	119115-3	Screw 螺絲	0	1	



RIGHT BEDPLATE FEED MECHANISM FOR 9910, 9920  
 右邊座傳動機構

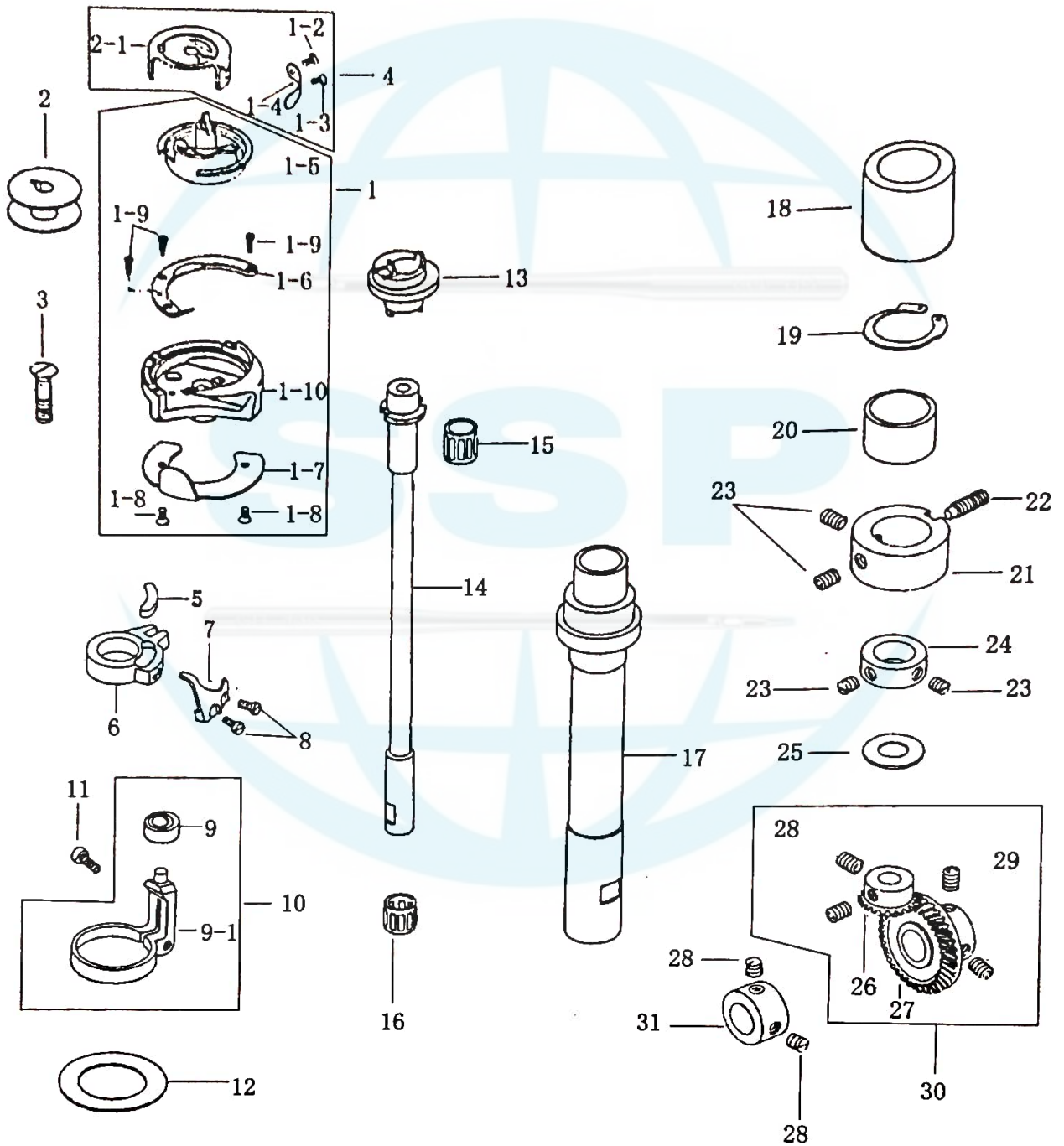

RIGHT BEDPLATE FEED MECHANISM FOR 9910, 9920  
右邊座傳動機構

Ref.No	Part No.	Name of Part	Amt.req.		Remarks
			9910	9920	
1	119716A	Hook Assy	1	1	
1-2	000390	Screw	1	2	
1-3	000928	Screw	1	1	
1-4	010166	Spring	1	1	
1-5	119487	B/C Base	1	1	
1-6	175136	Hook gib	1	1	
1-7	119377	Needle guard washer	1	1	
1-8	000219	Screw	2	2	
1-9	100529	Screw	3	6	
1-10	119376	Nook	1	1	
2	010079	Bobbin	1	1	
2-1	010158	Bibbin Case	1	2	
3	100205	Screw	1	1	
4	119716	Bobbin case Assy	1	1	
5	119128	Oil Felt	1	1	
6	119127	Rotating Hook Opener Bracket	1	1	
7	119129	Rotating Hook Opener	1	1	
8	108093	Screw	2	2	
9	694ZZ	Ball Bearing	1	1	(9)
9-1	119106-1	Driver	1	1	
10	119106	Driver	1	1	
11	108177	Screw	1	1	
12	119105	Washer	1	1	
13	119525-1	Hook Driver	1	1	
14	119525	Hook Shaft	1	1	
15	215031	Needle Bearing	1	1	
16	215028	Needle Bearing	1	1	
17	119524	Feed Wheel Shaft	1	1	
18	119979	Bushing	1	1	
19	664390	Retaining Ring	1	1	
20	175138	Bushing	1	1	
21	119107	Bushing	1	1	
22	119950	Screw	4	4	
23	341901	Screw	1	1	
24	131088	Collar	2	2	
25	125010	Washer(0.5)	1	1	
25-1	122718	Washer(0.1)	1	1	
25-2	125008	Washer(0.15)	1	1	
25-3	125009	Washer(0.2)	1	1	
26	119133-1	Bevel Gear(Small)	1	1	
27	119133-2	Bevel Gear(Large)	1	1	
28	700689	Screw	4	4	
29	341901-1	Screw	2	2	
30	119133	Gear Set	1	1	(26~29)
31	123778	Collar	1	1	

SPECIAL PARTS  
特殊配件

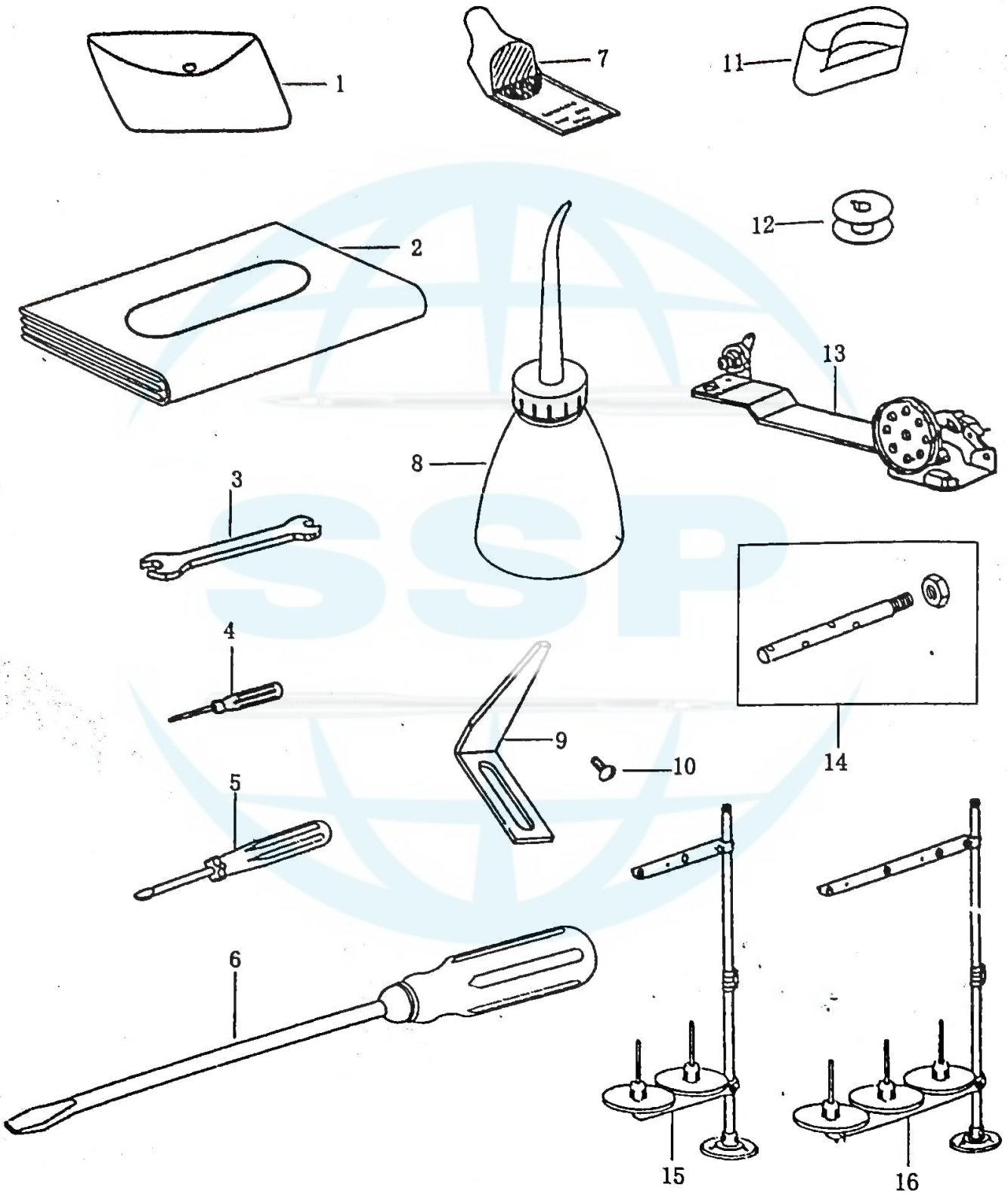



SPECIAL PARTS  
特殊配件

Ref.No	Part No.	Name of Part	Amt.req.		Remarks
			9910	9920	
1	123456	Accessory Bag			
2	029836	Vinyl Cover			
3	800110	Spanner			
4	129915	Screw Driver(Small)			
5	029946	Screw Driver(Middle)			
6	029007	Screw Driver(Large)			
7	134356	Needle			
8	029374	Oiler			
9	119089-1	Stitching Length Indicator			
10	100355	Screw			
11	032808	Head Cushion			
12	010079	Bobbin			
13	259431	Bobbin Winder			
14	119026	Spool Pin			
15	FPL2	Thread Stand(2-Pole)			
16	FPL3	Thread Stand(3-Pole)			

ACCESSORIES FOR 9910, 9920  
附件

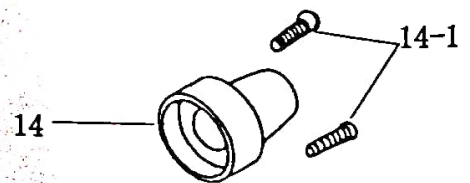
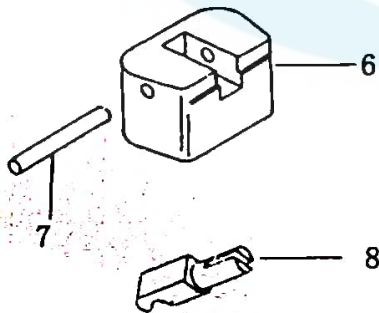
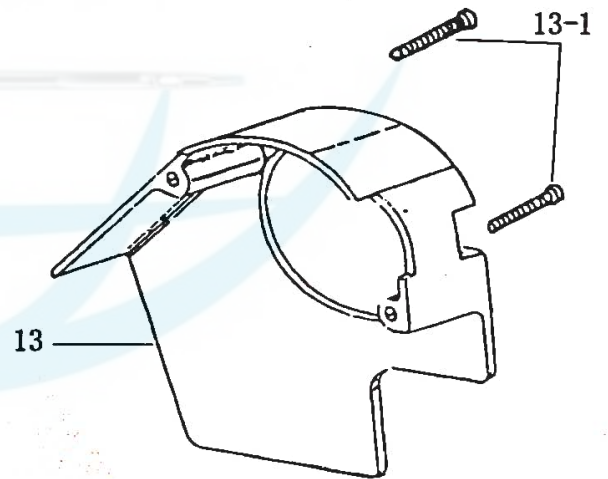
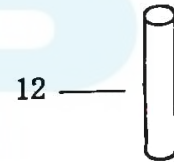
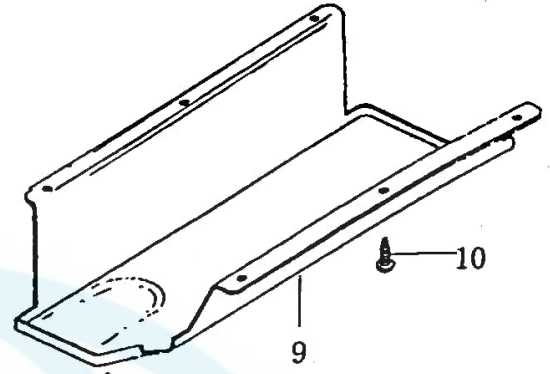
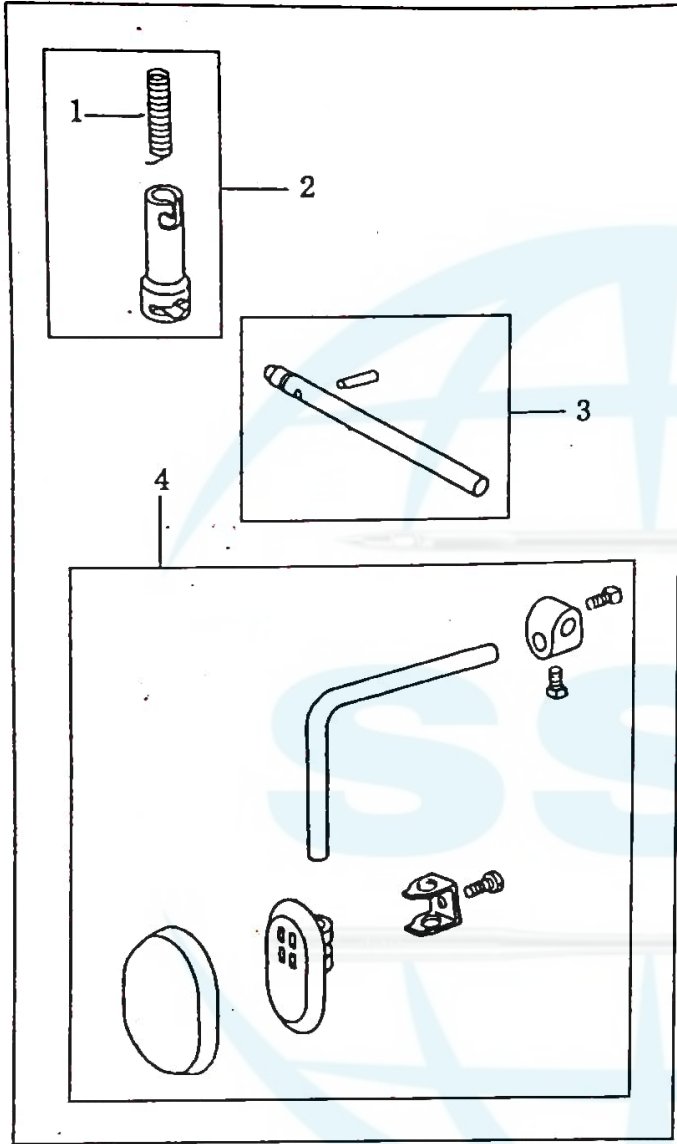

ACCESSORIES FOR 9910, 9920  
附件

Ref.No	Part No.	Name of Part	Amt.req.		Remarks
			9910	9920	
1	171543	Spring 彈簧	1	1	
2	171542	Knee Lever Coupling 腳押連杆頭	1	1	
3	171413	Knee Lever Rod 腳押軸	1	1	
4	171412	Knee Lever Assy 腳弓組	1	1	(2~4)
5	171411	Knee Lever Rod Assy 腳弓押組	1	1	
6	029934	Hinge Connection Seat 後鈕腳墊(大)	2	2	
7	030341	Pin 平行梢	2	2	
8	029450	Hinge Pin 後鈕鈎	2	2	
9	118636	Oil Pan 油槽	1	1	
10	460157	Screw 螺絲	6	6	
11	032717	Head Rest Wood 枕木	1	1	
12	032717-1	Housing Support Stud 固定梢	1	1	
13	119078	Belt Cover Set(Large) 皮帶蓋(大)	1	1	
13-1	119089-2	Screw 螺絲	2	2	
14	119088	Belt Cover Set(small) 皮帶蓋(小)	1	1	
14-1	119078-1	Screw 螺絲	2	2	



SPECIAL PARTS  
特殊配件



9920-1

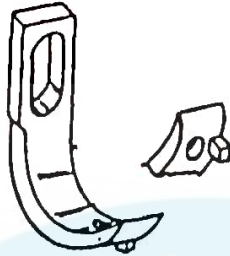

9920-2

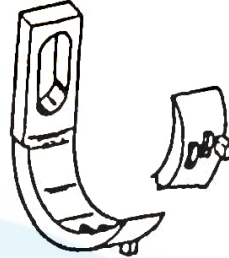

9920-3

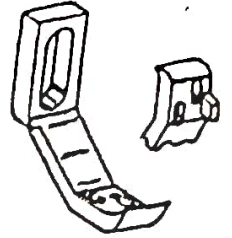

9920-4

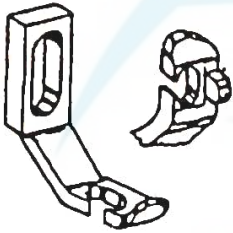

9920-5

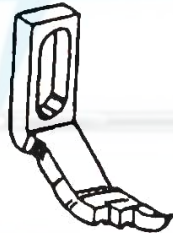

9920-6



9920-7



9920-8

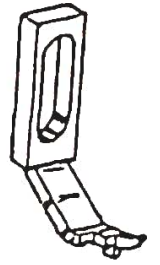

9920-9

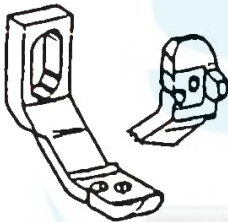

9920-10

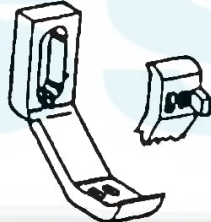

9920-11

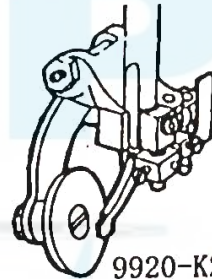

9920-K2

9920-12  
9920 Garge

