



1530 (直驱款/Direct drive)

1530BFT (自动款/Automatic)

产品使用说明书&产品零件图册

Manual book & parts book



01.	本体机构	01
02.	上轴主轴传动机构	03
03.	摆针、下轴、梭轴机构	05
04.	缝目、倒缝机构	07
05.	送布轴、抬牙轴机构	09
06.	抬压脚、松线机构	11
07.	自动剪线机构	13
08.	供油机构	15
09.	随机附件	17
10.	电气连接图	19

01 本体机构

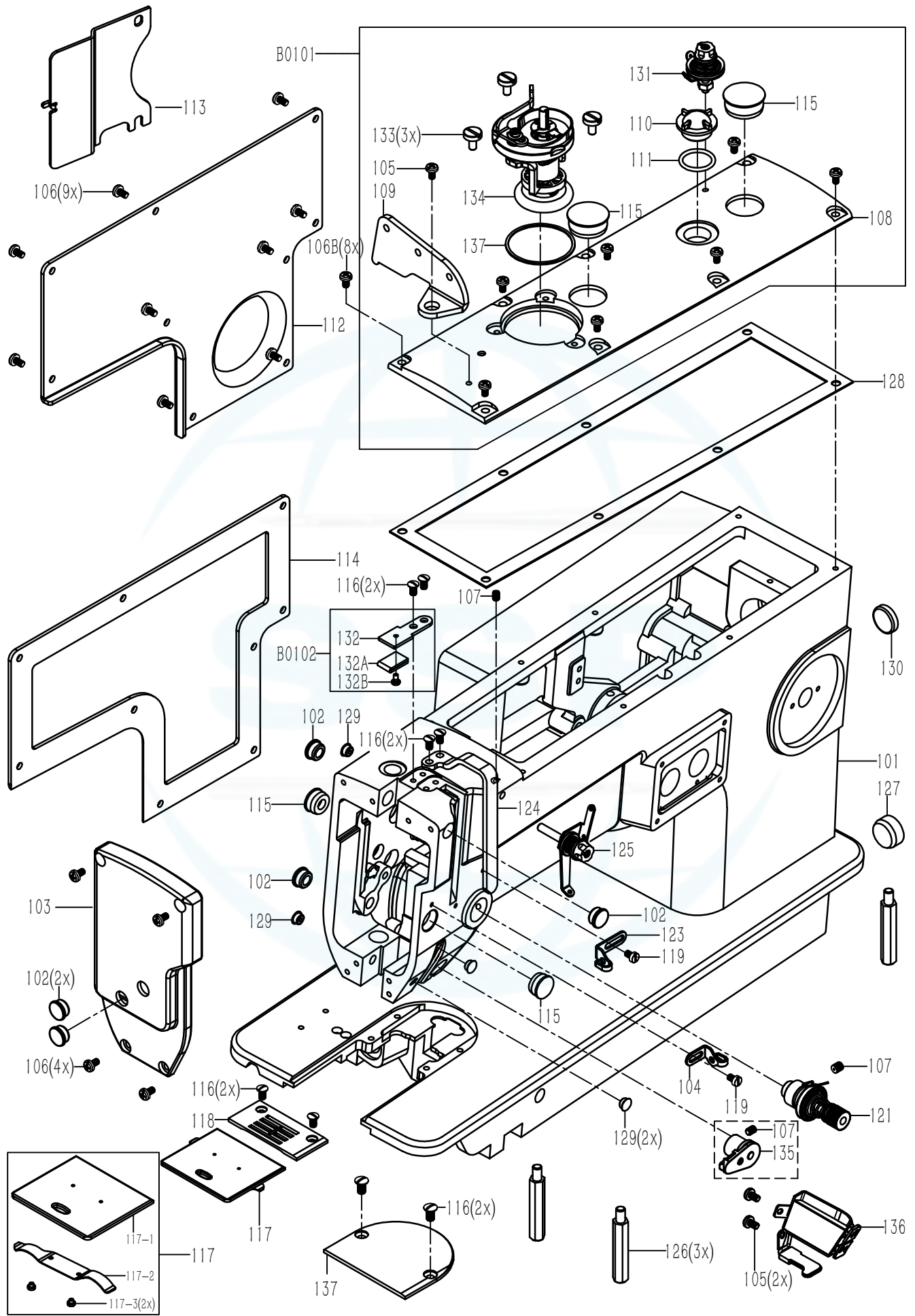

序号	图号	件号	名称	规格型号	数量	
					1530	1530BFT
B0101	Z5-ZJ38	950800412	顶盖部装		1	1
105	Z5-01-008	2212NS13001	十字圆柱头螺丝	SM11/64"-40×7	3x	3x
108	Z5-01-010	930800003	顶盖（喷后）		1x	1x
109	Z5-01-011	221213001	三眼线勾		1x	1x
110	Z5-01-012	221211001	油窗（含O型圈）		1x	1x
131	Z5-01-034-00	22121300700	底线夹线器组件		1x	1x
133	Z5-03-019	2212NS10010	圆柱头螺丝	SM3/16"-28×10	3x	3x
134	Z5-08-038-00	22123100100	一键式绕线夹线器组件		1x	1x
137	Z5-08-042	221222020	密封垫		1x	1x
B0102	Z5-ZJ37	950800411	摆针架毛毡部装		1	1
132	Z5-07-015	221212021	摆针架毛毡压板		1x	1x
132A	Z5-07-016	221223004	摆针架润滑毛毡		1x	1x
132B	GB/T67	S04275	开槽盘头螺钉	M2.5×4	1x	1x
101	Z5-01-001-00	930800002	壳体组件		1	1
102	Z5-01-004	221222001	橡皮塞	D=11	5	5
103	Z5-01-005	930800005	面板（喷后）		1	1
104	Z5-01-006	221213008	左线勾		1	1
106	Z5-01-036	2212NS13002	十字圆柱头螺丝	SM11/64"-40×10	13	13
106B	Z5-01-036B	2212NS10036	十字圆柱头螺丝	SM11/64"-40×12	8	8
107	Z5-01-009	2212NS11001	内六角紧定螺丝	SM11/64"-40×6	2	3
112	Z5-01-014	930800004	后盖板（喷后）		1	1
113	Z5-01-035	930800006	电线盖板（喷后）		1	1
114	Z5-01-015	221222004	后盖板油垫		1	1
115	Z5-01-007	221222002	橡皮塞	D=15.5	6	4
116	Z5-01-017	2212NS17001	开槽半沉头螺丝	SM11/64"-40×9	8	6
117	Z5-01-018-00	22121500300	推板组件		1	1
117-1	Z5-01-018-01	221215001	推板		1x	1x
117-2	Z5-01-018-02	221227001	推板簧		1x	1x
117-3	Z5-01-018-03	2212NS11007	推板簧螺钉		2x	2x
118	Z5-01-019	221215002	针板		1	1
119	Z5-01-020	2212NS11002	圆柱头螺丝	SM9/64"-40×6	2	2
121	Z5-01-023-00	22121300200	夹线器组件		1	1
123	Z5-01-025	221213003	上座右线勾		1	1
124	Z5-01-026	930800009	挑线杆防护罩(涂后)		1	1
125	Z5-01-027-00	22121300400	小夹线器组件		1	1
126	Z5-01-028	221202001	底板支撑杆		3	3
127	Z5-01-029	221222006	橡皮塞	D=20	1	1
128	Z5-01-030	221222007	顶盖油垫		1	1
129	Z5-01-031	221222008	橡皮塞	D=7	4	4
130	Z5-01-032	221222009	橡皮塞	D=19	1	1
135	Z5-08-041	22123001000	电子夹线器组件		0	1
136	Z5-08-035-01	22123002100	倒缝开关组件(杰克)		1	1
137	Z5-08-030-J	221212027	剪线刀组固定板(直驱)		1	0

02 上轴、主轴传动机构

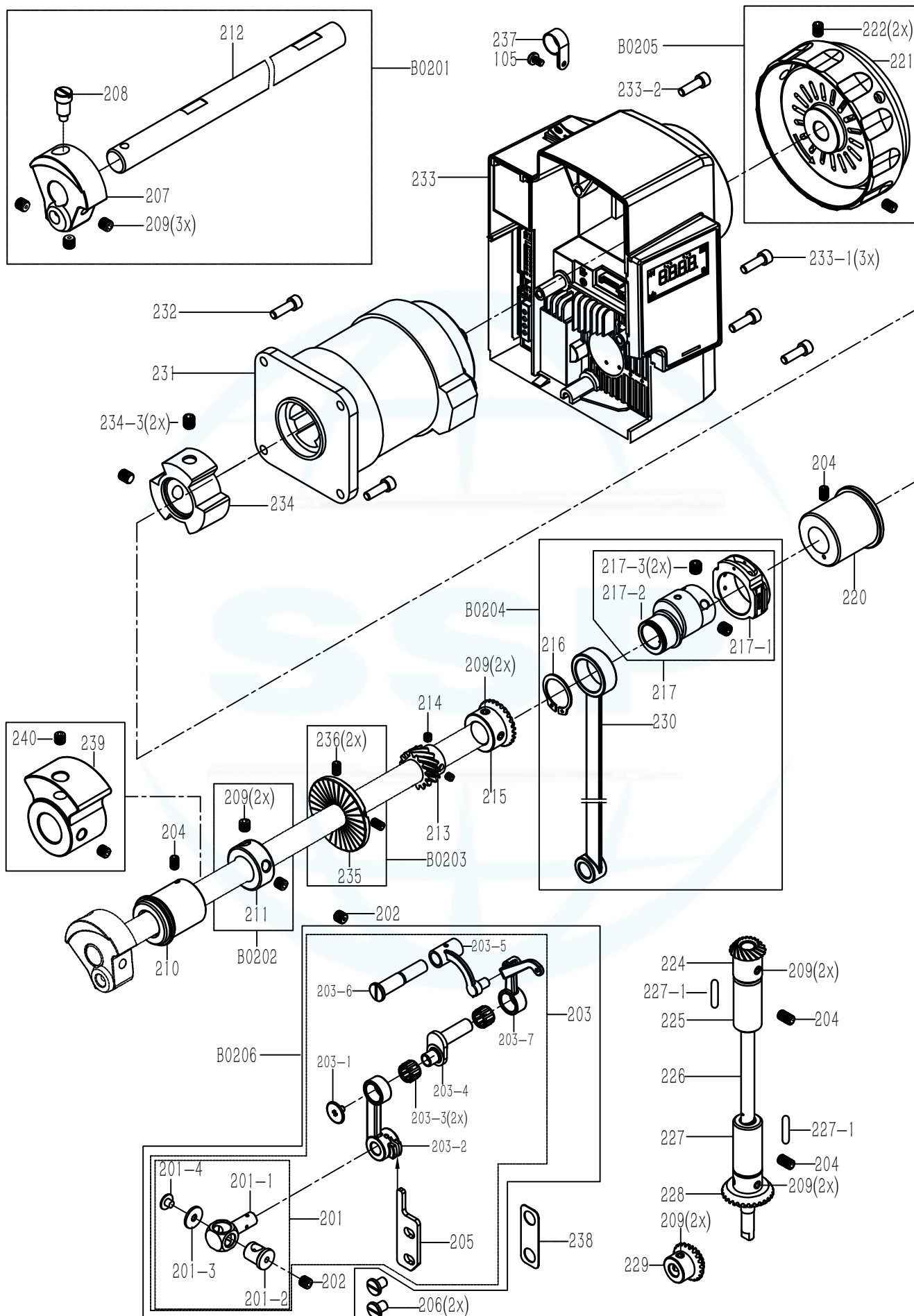

序号	图号	件号	名称	规格型号	数量	
					1530	1530BFT
207	Z5-02-017	221204002	针杆曲柄		1x	1x
208	Z5-02-018	2212NS10005	螺丝	SM9/32"-28×10	1x	1x
209	Z5-02-025	2212NS10007	内六角紧定螺丝	SM1/4-40"×6	3x	3x
212	Z5-02-022	221202006	上轴		1x	1x
B0203	Z5-ZJ04	950800378	绕线器驱动轮部装		1	1
235	Z5-08-037	221235002	绕线器驱动轮		1x	1x
236	GB/T80	S10081	内六角凹端紧定螺	M5×8	2x	2x
B0204	Z5-ZJ05	950800379	送步偏心轮组件部装		1	1
216	GB/T894.1	H03069	轴用弹性挡圈	20	1x	1x
217	Z5-02-028-00	22121000200	送布偏心轮组件		1x	1x
217-1	Z5-02-028-01	221209002	牙叉滑块		1x	1x
217-2	Z5-02-028-02	221210001	送布偏心轮		1x	1x
217-3	Z5-01-024	2212NS10001	内六角紧定螺丝	SM15/64"-28×6	2x	2x
230	Z5-02-042	221205004	抬牙连杆		1x	1x
B0205	Z5-ZJ20	950800394	手轮部装		1	1
221	Z5-02-032	930800007	手轮（喷后）		1x	1x
222	GB/T80	S10086	内六角凹端紧定螺钉	M6×8	2x	2x
B0206	Z5-02-007	22123800300	挑线杆大组件		1	1
201	Z5-02-001-00	22120200200	针杆接头组件		1x	1x
201-1	Z5-02-001-01	221202003	针杆接头		1x	1x
201-2	Z5-02-001-02	221202004	针杆接头转轴		1x	1x
201-3	Z5-02-001-03	221228001	垫片		1x	1x
201-4	Z5-02-001-04	2212NS10002	针杆接头螺钉	SM11/64"-40×3.5	1x	1x
202	Z5-01-009	2212NS11001	内六角紧定螺丝	SM11/64"-40×6	1x	1x
202	Z5-01-009	2212NS11001	内六角紧定螺丝	SM11/64"-40×6	1x	1x
203	Z5-02-007-00	22123800200	挑线杆组件		1x	1x
204	Z5-02-015	2212NS10004	内六角紧定螺丝	SM15/64"-28×10	4	4
205	Z5-02-016	221209001	针杆连杆导位块		1x	1x
206	Z5-02-002	2212NS10003	圆柱头螺丝	SM11/64"-40×6	2	2
210	Z5-02-019	221203001	上轴左套管		1	1
213	Z5-02-023	221225001	摆针传动齿（上）		1	1
214	Z5-02-024	2212NS10006	内六角紧定螺丝	SM11/64"-40×4	2	2
215	Z5-02-026	221225002	上轴齿轮		1	1
220	Z5-02-031	221203003	上轴右套管		1	1
224	Z5-02-035	221225003	竖轴上齿轮		1	1
225	Z5-02-037	221203004	竖轴上套管		1	1
226	Z5-02-038	221202007	竖轴		1	1
227	Z5-02-039	221203005	竖轴下套管		1	1
227-1	Z5-02-039-01	221223005	套管油棉		2	2
228	Z5-02-040	221225004	竖轴下齿轮		1	1
229	Z5-02-041	221225005	下轴右齿轮		1	1
231	Z5-08-001	221233001	电机		1	1
232	GB/T70.1	S05954	内六角圆柱头螺钉	M5×16	4	4
233	Z5-08-002	221230002	电控		0	1
	Z5-08-002-J	22123001300	直驱电控		1	0
233-1	GB/T70.1	S05109	内六角圆柱头螺钉	M5*35	3	3
233-2	GB/T70.1	S05955	内六角圆柱头螺钉	M5*20	1	1
234	Z5-08-036B	22121202400	电机联轴器组件		1	1
234-1	Z5-08-036B-01	221212024	电机联轴本体		1x	1x
234-2	Z5-08-036B-02	221222022	电机联轴器橡胶套		1x	1x
234-3	9910-094	1550NS14001	内六角紧定螺钉	M6×0.75-6	2x	2x
237	591-857	155211010	油管护架		1	1
238	Z5-02-016-01	221228014	调整垫片		2	2
239	Z5-02-021-1	221209018	平衡块		1x	1x
240		1552NS10060	紧定螺钉	M6×0.75×8	2x	2x
105	Z5-01-008	2212NS13001	十字圆柱头螺丝	SM11/64"-40×7	1	1

03 摆针、下轴、梭轴机构

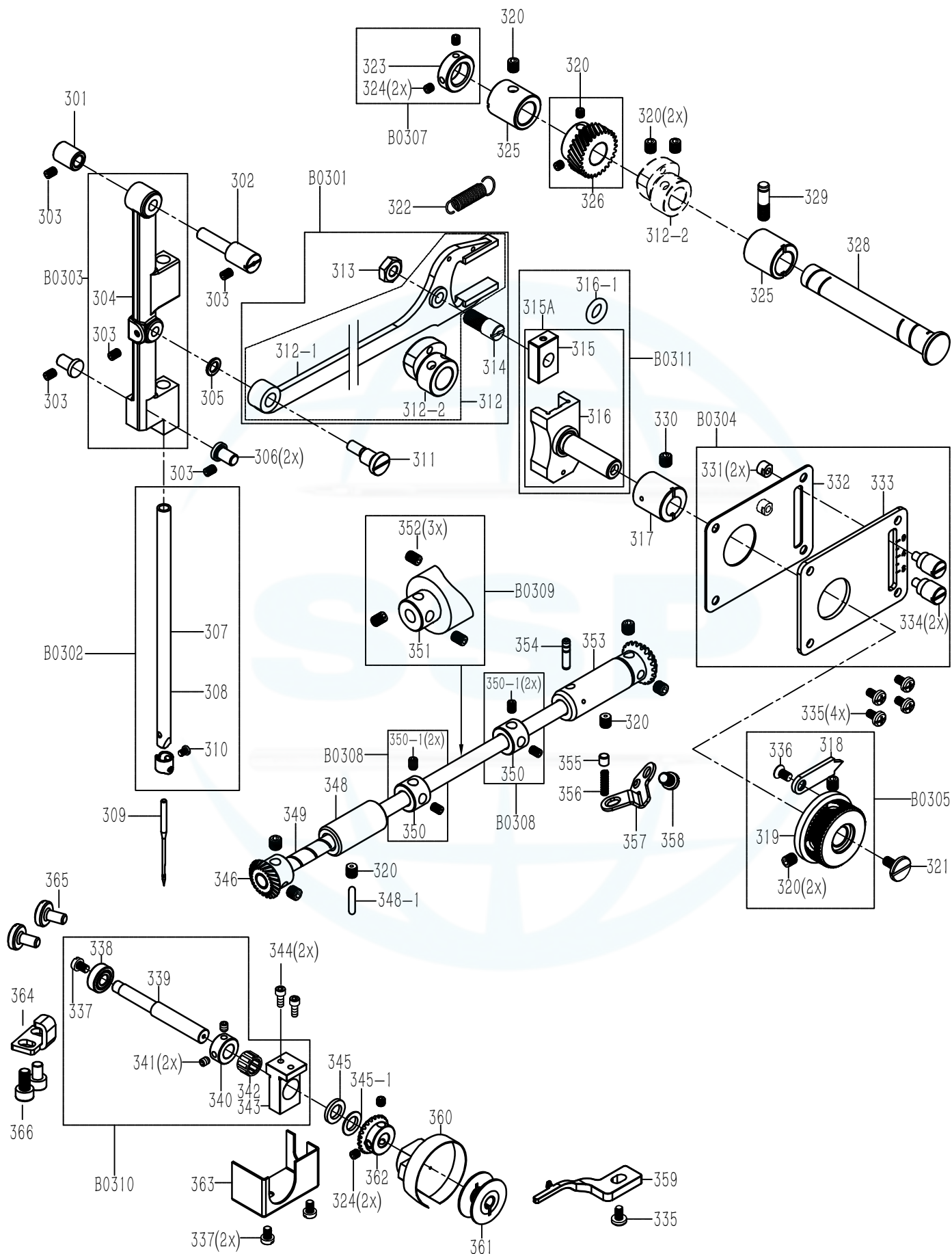

序号	图号	件号	名称	规格型号	数量	
					1530	1530BFT
312	Z5-03-012A	22121001000	摆针二又凸轮组件		1	1
312-1	Z5-03-012	221205005	摆针传动二又		1x	1x
312-2	Z5-03-024	221210005	摆针传动偏心轮		1x	1x
313	Z5-03-013	2212NS16001	螺母	SM9/32"-28×4	1x	1x
314	Z5-03-014	221202010	传动二又滑块轴		1x	1x
B0302	Z5-ZJ10	950800384	针杆部装		1	1
307	Z5-03-007	221202009	针杆		1x	1x
308	Z5-03-008	221213005	针杆过线环		1x	1x
310	Z5-03-010	2212NS10009	圆柱头螺丝	SM1/8"-44×4	1x	1x
B0303	Z5-ZJ12	950800386	摆针架部装		1	1
303	Z5-01-009	2212NS11001	内六角紧定螺丝	SM11/64"-40×6	1	1
304	Z5-03-004	221234001	摆针架		1	1
B0304	Z5-ZJ13	950800387	针摆指示板部装		1	1
331	Z5-03-027	2212NS16002	螺母	SM11/64"-40×3	2	2
332	Z5-03-028	221222010	摆幅指示板油垫		1	1
333	Z5-03-029	221237001	摆幅指示板		1	1
334	Z5-03-030	2212NS10012	滚花螺丝	SM11/64"-40	2	2
B0305	Z5-ZJ14	950800388	摆幅手转轮部装		1	1
318	Z5-03-018	221217001	摆幅指针		1x	1x
319	Z5-03-009	221210004	摆幅手转轮		1x	1x
320	Z5-01-024	2212NS10001	内六角紧定螺丝	SM15/64"-28×6	2x	2x
336	Z5-01-017	2212NS17001	开槽半沉头螺丝	SM11/64"-40×9	1x	1x
320	Z5-01-024	2212NS10001	内六角紧定螺丝	SM15/64"-28×6	2x	2x
B0307	Z5-ZJ16	950800390	摆针传动轴挡圈部装		1	1
323	Z5-03-021	221208001	摆针传动轴挡圈		1x	1x
324	Z5-02-024	2212NS10006	内六角紧定螺丝	SM11/64"-40×4	2x	2x
B0308	Z5-ZJ26	950800400	下周挡圈部装		2	2
350	Z5-03-044	221208003	下轴挡圈		2x	2x
350-1	Z5-01-024	2212NS10001	内六角紧定螺丝	SM15/64"-28×6	4x	4x
B0309	Z5-ZJ27	950800401	剪线凸轮部装		1	1
351	Z5-08-024C	221210009	剪线凸轮		1x	1x
352	9910-094	1550NS14001	内六角凹端紧定螺钉	M6×0.75×6	3x	3x
B0310	Z5-ZJ31	950800405	梭轴及梭轴座部装		1	1
337	Z5-01-020	2212NS11002	圆柱头螺丝	SM9/64"-40×6	1x	1x
338	GB/T294	B01066	深沟球轴承	619/6	1x	1x
339	Z5-03-034	221202012	梭轴		1x	1x
340	Z5-03-033	221208002	梭轴挡圈		1x	1x
341	Z5-02-024	2212NS10006	内六角紧定螺丝	SM11/64"-40×4	2x	2x
342	Z5-02-007-03	221224001	滚针轴承	Φ8×Φ12×8	1x	1x
343	Z5-03-035	221209005	梭轴座		1x	1x
B0311	Z5-ZJ18	950800392	滑块部装		1	1
315A	Z5-03-015-00	22120901500	传动二又滑块组件	组件供应	1x	1x
315	Z5-03-015	221209003	传动二又滑块		1x	1x
316	Z5-03-016	221209004	传动二又滑块座		1x	1x
316-1	Z5-03-031	221222021	O型圈	φ8×1.8	1x	1x
301	Z5-03-001	221203006	摆针架悬吊轴套		1	1
302	Z5-03-002	221202008	摆针架悬吊轴		1	1
303	Z5-01-009	2212NS11001	内六角紧定螺丝	SM11/64"-40×6	4	4
305	Z5-03-005	221228002	垫片		1	1
306	Z5-03-006	221226001	摆针架定位销		2	2
309		155217001	车针	TNC/DP*5*16#	1	1
311	Z5-03-011	221210003	偏心销		1	1
317	Z5-03-017	221203007	二又滑块座套		1	1
320	Z5-01-024	2212NS10001	内六角紧定螺丝	SM15/64"-28×6	5	5
321	Z5-03-019	2212NS10010	圆柱头螺丝	SM3/16"-28×10	1	1
322	Z5-03-020	221227002	摆针传动二又拉簧		1	1
325	Z5-03-022	221203008	摆针传动轴套		2	2
326	Z5-03-023	221225006	摆针传动齿轮下		1	1
328	Z5-03-025	221202011	摆针转动轴		1	1
329	Z5-03-026	2212NS10011	拉簧固定螺钉	SM15/64"-28	1	1
330	Z5-02-015	2212NS10004	内六角紧定螺丝	SM15/64"-28×10	1	1
335	Z5-01-036	2212NS13002	十字圆柱头螺丝	SM11/64"-40×10	5	5
337	Z5-01-020	2212NS11002	圆柱头螺丝	SM9/64"-40×6	2	2
344	Z5-03-036	2212NS13003	梭轴座螺钉		2	2
345	Z5-03-038	221228003	梭轴垫片		1	1
345-1	9910-256	155128001	调整垫片(0.1mm)		1	1
346	Z5-03-040	221225007	下轴齿轮		1	1
347	Z5-02-025	2212NS10007	内六角紧定螺丝	SM1/4"-40×6	2	2
348	Z5-02-037	221203004	竖轴上套管		1	1
348-1	Z5-02-039-01	221223005	套管油棉		1	1
349	Z5-03-042	221202013	下轴		1	1
353	Z5-03-045	221203009	下轴右套		1	1
354	Z5-03-046	221221001	下轴右套油管		1	1
355	Z5-03-047	221209006	柱塞		1	1
356	Z5-03-048	221227003	柱塞弹簧		1	1
357	Z5-03-049	221212003	挡板		1	1
358	Z5-03-050	2212NS10014	圆柱头螺丝	SM15/64"-28×8	1	1
359	Z5-03-051	221234002	旋梭定位勾		1	1
360-1	Z5-03-053B-01	221218005	梭壳		1x	1x
360-2	Z5-03-053-02	22121800200	旋梭		1x	1x
361	Z5-03-054	221231015	梭芯		1	1
362	Z5-03-056	221225008	梭轴齿轮		1	1
363	Z5-03-057	221211002	黄油盒		1	1
364	Z5-03-058	221212036	折弯板		1	1
365	9922BFT-F003A-3	1552NS11004	线架盘螺钉		2	2
366		S05992	内六角圆柱头螺钉	M4*6	2	2

04 缝目、倒缝机构

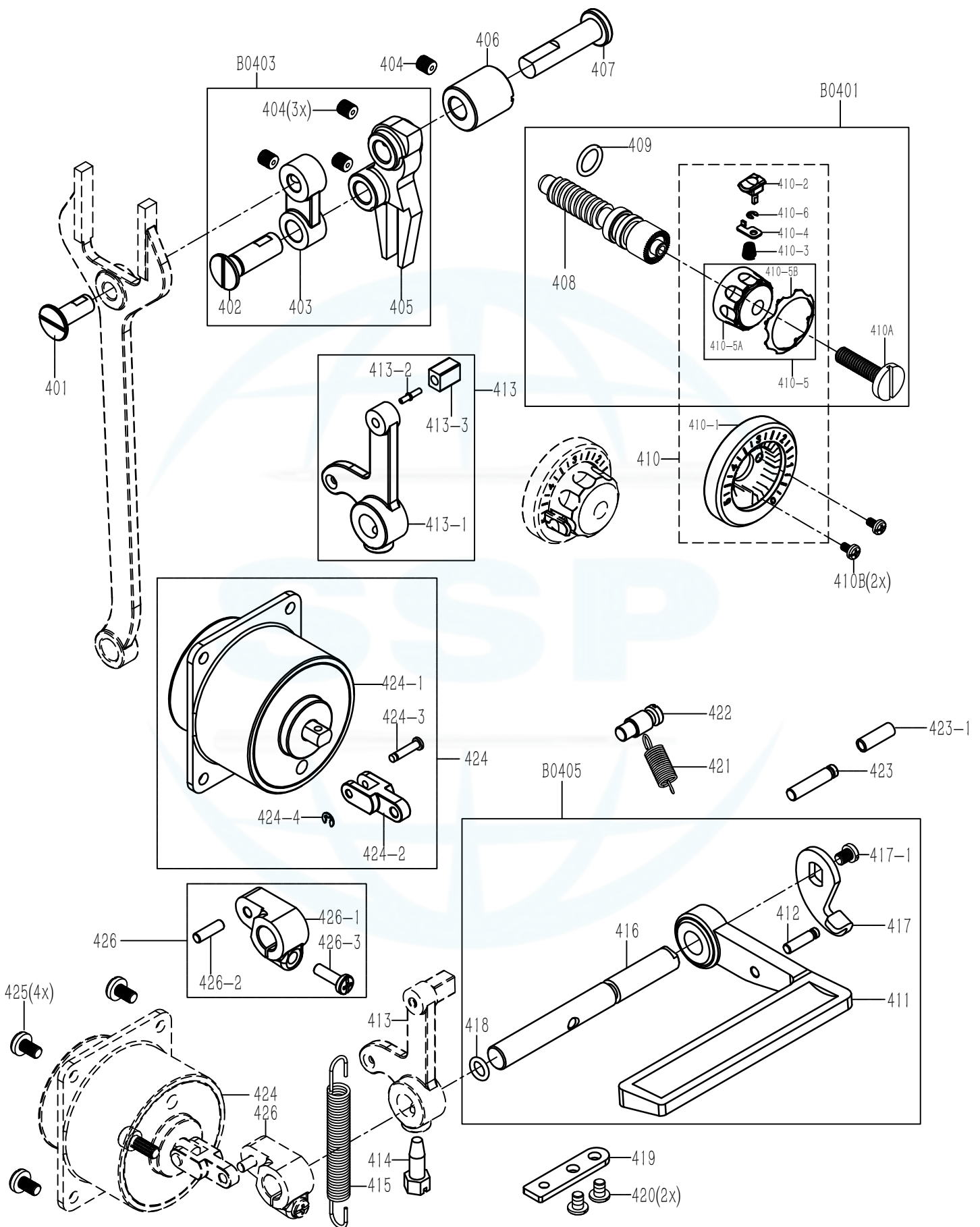

序号	图号	件号	名称	规格型号	数量	
					1530	1530BFT
408	Z5-04-007	2212NS10015	针距调节螺丝		1x	1x
409	Z5-04-010	221222011	O型圈	φ9.5*2.5	1x	1x
410-2	A4-0562	13811009	标盘按钮		1x	1x
410-3	Z5-04-011-03	221227014	按钮复位簧		1x	1x
410-4	Z5-04-011-04	221212022	上限位片		1x	1x
410-5	A4-0614	1381100700	标盘旋钮组件		1x	1x
410-6	GB/T896	H05915	开口挡圈	3.5	1x	1x
410A	Z5-04-013	2212NS10016	圆柱头螺丝	SM3/16"-28×15	1x	1x
B0403	Z5-ZJ19	950800393	针距调节摆杆部装		1	1
402	Z5-04-002	221202015	针距连杆铰链轴		1x	1x
403	Z5-04-003	221205006	针距连杆		1x	1x
404	Z5-01-024	2212NS10001	内六角紧定螺丝	SM15/64"-28×6	3x	3x
405	Z5-04-004	221205007	针距调节摆杆		1x	1x
B0405	Z5-ZJ21	950800395	倒缝操纵杆部装		1	1
411	Z5-04-014	930800008	倒缝操纵杆(喷后)		1x	1x
412	Z5-04-014-01	221226011	倒缝扳手销		1x	1x
416	Z5-04-018	221202017	倒缝操纵杆轴		1x	1x
417	Z5-04-019	221212016	倒缝扳手板		1x	1x
417-1	Z5-03-019	2212NS10010	开槽圆柱头螺钉	SM3/16"-28×10	1x	1x
418	Z5-04-021	221222018	O型圈	Φ6.3×1.8	1x	1x
401	Z5-04-001	221202014	牙叉铰链轴		1	1
404	Z5-01-024	2212NS10001	内六角紧定螺丝	SM15/64"-28×6	1	1
406	Z5-04-005	221203010	针距调节摆杆轴套		1	1
406-1	GB/T 80	S10075	内六角凹端紧定螺钉	M4×5(发黑)	1	1
407	Z5-04-006	221202016	针距调节摆杆轴		1	1
410	Z5-04-011-00		针距旋钮		1	1
410-1	Z5-04-011-01	221222012	固定表盘		1	1
410B	Z5-01-036	2212NS13002	十字圆柱头螺丝	SM11/64"-40×10	2	2
413	Z5-04-015-00	22120400300	倒缝操纵曲柄组件		1	1
413-1	Z5-04-015-01	221204012	倒缝操纵曲柄		1x	1x
413-2	Z5-04-015-02	221226007	倒缝曲柄销		1x	1x
413-3	Z5-04-015-03	221209014	倒缝曲柄滑块		1x	1x
414	Z5-04-016	2212NS10017	紧定螺丝	SM15/64"-28×10	1	1
415	Z5-04-017	221227005	操作杆曲柄弹簧		1	1
419	Z5-04-022	221212020	倒缝拉簧固定板		1	1
420	Z5-02-002	2212NS10003	圆柱头螺丝	SM11/64"-40×6	2	2
421	Z5-04-023	221227013	倒缝扳手板拉簧		1	1
422	Z5-04-024	221226010	拉簧固定销		1	1
423	Z5-06-017	221226003	拉簧销		1	1
423-1	Z5-06-017-01	221221008	橡胶套		1	1
424	Z5-08-025-00	22123000500	倒缝电磁铁大组件		0	1
424-1	Z5-08-025-01	22123000100	倒缝电磁铁组件		0	1x
424-2	Z5-08-025-02	221209012	倒缝电磁铁连接块		0	1x
424-3	Z5-08-025-03	221226005	倒缝电磁铁连接销		0	1x
424-4	GB/T896	H03057	开口挡圈	2.5	0	1x
425	Z5-01-036	2212NS13002	十字圆柱头螺丝	SM11/64"-40×10	0	4
426	Z5-08-029-00	22120401100	自动倒缝曲柄组件		0	1
426-1	Z5-08-029-01	221204013	自动倒缝曲柄		0	1x
426-2	Z5-08-029-02	221226008	自动倒缝曲柄销		0	1x
426-3	Z5-08-029-03	2212NS10023	曲柄螺钉	SM3/16"-32×14	0	1x

05 送布轴、抬牙轴机构

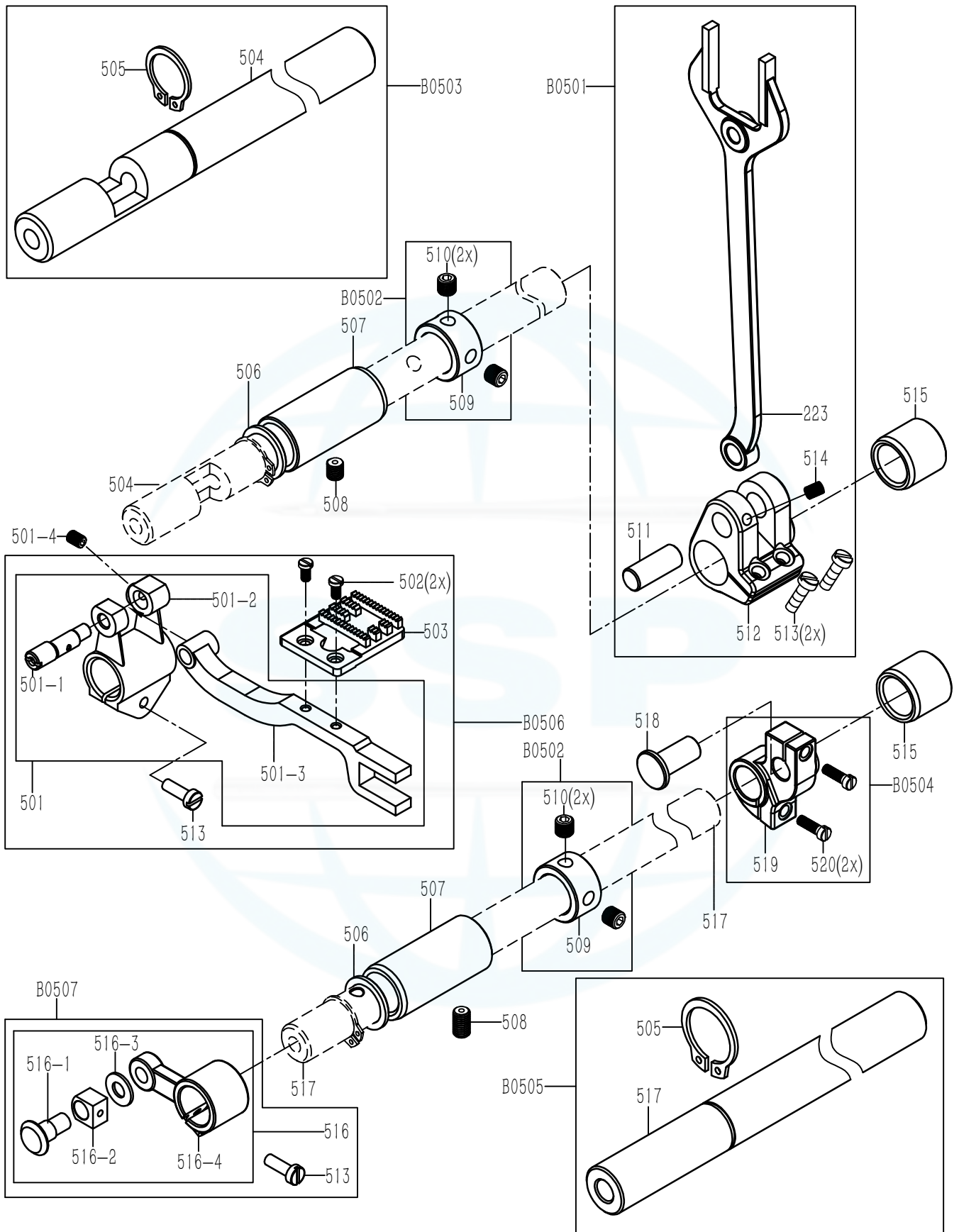

序号	图号	件号	名称	规格型号	数量	
					1530	1530BFT
223	Z5-02-034	221205003	送布传动牙叉		1x	1x
511	Z5-05-013	221202019	送布轴曲柄铰链轴		1x	1x
512	Z5-05-007	221204005	送布轴曲柄（右）		1x	1x
513	Z5-05-008	2212NS11003	圆柱头螺丝	SM11/64"-40×12	2x	2x
514	Z5-01-009	2212NS11001	内六角紧定螺丝	SM11/64"-40×6	1x	1x
B0502	Z5-ZJ24	950800398	送布轴挡圈部装		2	2
509	Z5-05-012	221208004	送布轴挡圈		2x	2x
510	Z5-02-025	2212NS10007	内六角紧定螺丝	SM1/4-40"×6	4x	4x
B0503	Z5-ZJ25	950800399	送步轴及卡环部装		1	1
504	Z5-05-006	221202018	送布轴		1x	1x
505	GB/T894.1	H03067	轴用弹性挡圈	15	1x	1x
B0504	Z5-ZJ28	950800402	抬牙右曲柄部装		1	1
519	Z5-05-023	221204008	抬牙右曲柄		1x	1x
520	Z5-05-024	2212NS11005	螺钉	SM3/16"-28×15	2x	2x
B0505	Z5-ZJ29	950800403	抬牙轴及卡环部装		1	1
505	GB/T894.1	H03067	轴用弹性挡圈	15	1x	1x
517	Z5-05-021	221202021	抬牙轴		1	1
B0506	Z5-ZJ32	950800406	牙架及送布牙部装		1	1
501	Z5-05-003-00	22120700100	牙架组件		1x	1x
501-1	Z5-05-003-01	221210006	牙架偏心销		1x	1x
501-2	Z5-05-003-02	221204004	牙架曲柄		x	x
501-3	Z5-05-003-03	221206001	牙架		1x	1x
501-4	Z5-02-024	2212NS10006	内六角紧定螺丝	SM11/64"-40×4	1x	1x
502	Z5-05-004	2212NS10018	送料牙螺钉	SM1/8"-44×6	2x	2x
503	Z5-05-005	221214001	送布牙		1x	1x
513	Z5-05-008	2212NS11003	圆柱头螺丝	SM11/64"-40×12	1x	1x
B0507	Z5-ZJ33	950800407	抬牙轴左曲柄部装		1	1
513	Z5-05-008	2212NS11003	圆柱头螺丝	SM11/64"-40×12	1x	1x
516	Z5-05-015-00	22120400600	抬牙轴左曲柄组		1x	1x
516-1	Z5-05-015-01	221202020	抬牙叉滑块轴		1x	1x
516-2	Z5-05-015-02	221209007	抬牙叉滑块		1x	1x
516-3	Z5-05-015-03	221228005	垫片		1x	1x
516-4	Z5-05-015-04	221204007	抬牙轴左曲柄		1x	1x
506	Z5-05-010	221228004	垫片		2	2
507	Z5-05-020	221203012	抬牙轴座套		2	2
508	Z5-01-024	2212NS10001	内六角紧定螺丝	SM15/64"-28×6	2	2
515	Z5-05-014	221203011	送布轴右套		2	2
518	Z5-05-022	221202022	抬牙轴曲柄铰链轴		1	1

06 抬压脚、松线机构

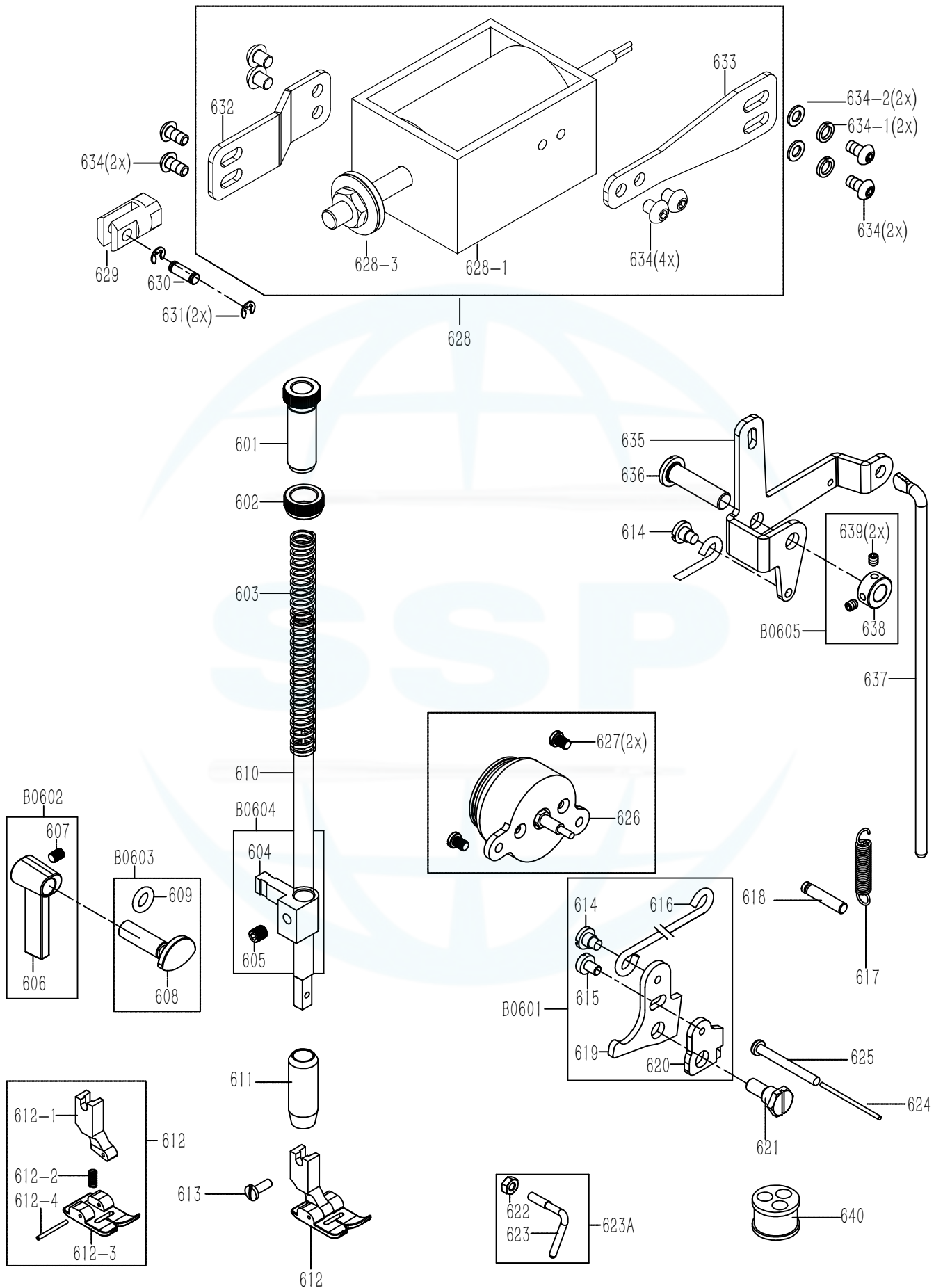

序号	图号	件号	名称	规格型号	数量	
					1530	1530BFT
614	Z5-06-010	2212NS20001	轴位螺钉	SM3/16"-28×3.5	1x	1x
615	Z5-06-011	2212NS11004	圆柱头螺丝	SM11/64"-40×6.5	1x	1x
616	Z5-06-012	221205009	抬压脚拉杆		1x	1x
619	Z5-06-018	221212005	膝控提升杠杆(左)		1x	1x
620	Z5-06-019	221212006	松线板		1x	1x
B0602	Z5-ZJ07	950800381	抬牙扳手部装		1	1
606	Z5-06-005	221204010	抬压扳手		1x	1x
607	Z5-01-009	2212NS11001	内六角紧定螺丝	SM11/64"-40×6	1x	1x
B0603	Z5-ZJ08	950800382	压脚抬升偏心轮部装		1	1
608	Z5-06-006	221210007	压脚抬升偏心轮		1x	1x
609	Z5-06-024	221222013	O型圈	4.5×1.8	1x	1x
B0604	Z5-ZJ09	950800383	压脚导位块部装		1	1
604	Z5-06-004	221209008	压杆导位块		1x	1x
605	Z5-01-024	2212NS10001	内六角紧定螺丝	SM15/64"-28×6	1x	1x
B0605	Z5-ZJ34	950800408	抬压脚转轴定环部装		1	1
638	9910-250G	155008007	定环		1x	1x
639	9910-094	1550NS14001	内六角凹端紧定螺钉	M6×0.75×6	2x	2x
601	Z5-06-001	2212NS16003	调压螺套		1x	1x
602	Z5-06-002	2212NS16004	调压螺套螺母		1x	1x
603	Z5-06-003	221227006	压脚杆弹簧		1	1
610	Z5-06-007	221202023	压脚杆		1	1
611	Z5-06-008	221203013	压脚杆下套		1	1
612	Z5-06-009-00	22121600100	压脚组件		1	1
612-1	Z5-06-009-01	221216002	活动脚柄		1x	1x
612-2	Z5-06-009-02	221227011	压脚弹簧		1x	1x
612-3	Z5-06-009-03	221216003	压脚底板		1x	1x
612-4	Z5-06-009-04	221226009	压脚摆销		1x	1x
613	Z5-06-025	2212NS10019	压脚螺钉	SM9/64"-40×9	1	1
614	Z5-06-010	2212NS20001	轴位螺钉	SM3/16"-28×3.5	1	1
617	Z5-06-016	221227007	复原弹簧		1	1
618	Z5-06-017	221226003	拉簧销		1	1
621	Z5-06-021	2212NS10020	松线凸轮螺钉	SM15/64"-28×11	1	1
623A	Z5-06-023-00	22121300900	缓线勾及螺母组件		1	1
622	Z5-06-022	2212NS16005	螺母	SM9/64"-40×3	1x	1x
623	Z5-06-023	221213006	固定式缓线勾		1x	1x
624	Z5-08-031	221226006	松线销		1	1
625	Z5-08-032	221202028	松线顶杆		1	1
626	Z5-08-033-00	22123000600	松线电磁铁组件		0	1
627	Z5-01-036	2212NS13002	十字圆柱头螺丝	SM11/64"-40×10	0	2
628	Z5-08-004-00	22123000300	抬压脚电磁铁组件		0	1
628-1	Z5-08-004-01		抬压脚电磁铁主体		0	1x
632	Z5-08-007	221212009	抬压电磁铁固定板1		0	1x
633	Z5-08-008	221212010	抬压电磁铁固定板2		0	1x
634	GB/T70.2	S17908	内六角平圆头螺钉	M5×10	0	4x
629	Z5-08-005	221209009	抬压脚电磁铁接头		0	1
630	Z5-08-006	221226004	抬压脚驱动销		0	1
631	GB/T896	H05915	开口挡圈	3.5	0	2
634	GB/T70.2	S17908	内六角平圆头螺钉	M5×10	0	4
634-1	GB/T93	W02001	弹簧垫片	5	0	2x
634-2	GB/T95	W01146	平垫	5	0	2x
635	Z5-08-009	221212011	抬压脚驱动板		1	1
636	Z5-08-010	221202024	抬压脚转轴		1	1
637	Z5-08-011	221212012	抬压脚顶杆		1	1
640	Z5-07-012	221222019	电线孔塞		1	1

07 自动剪线机构

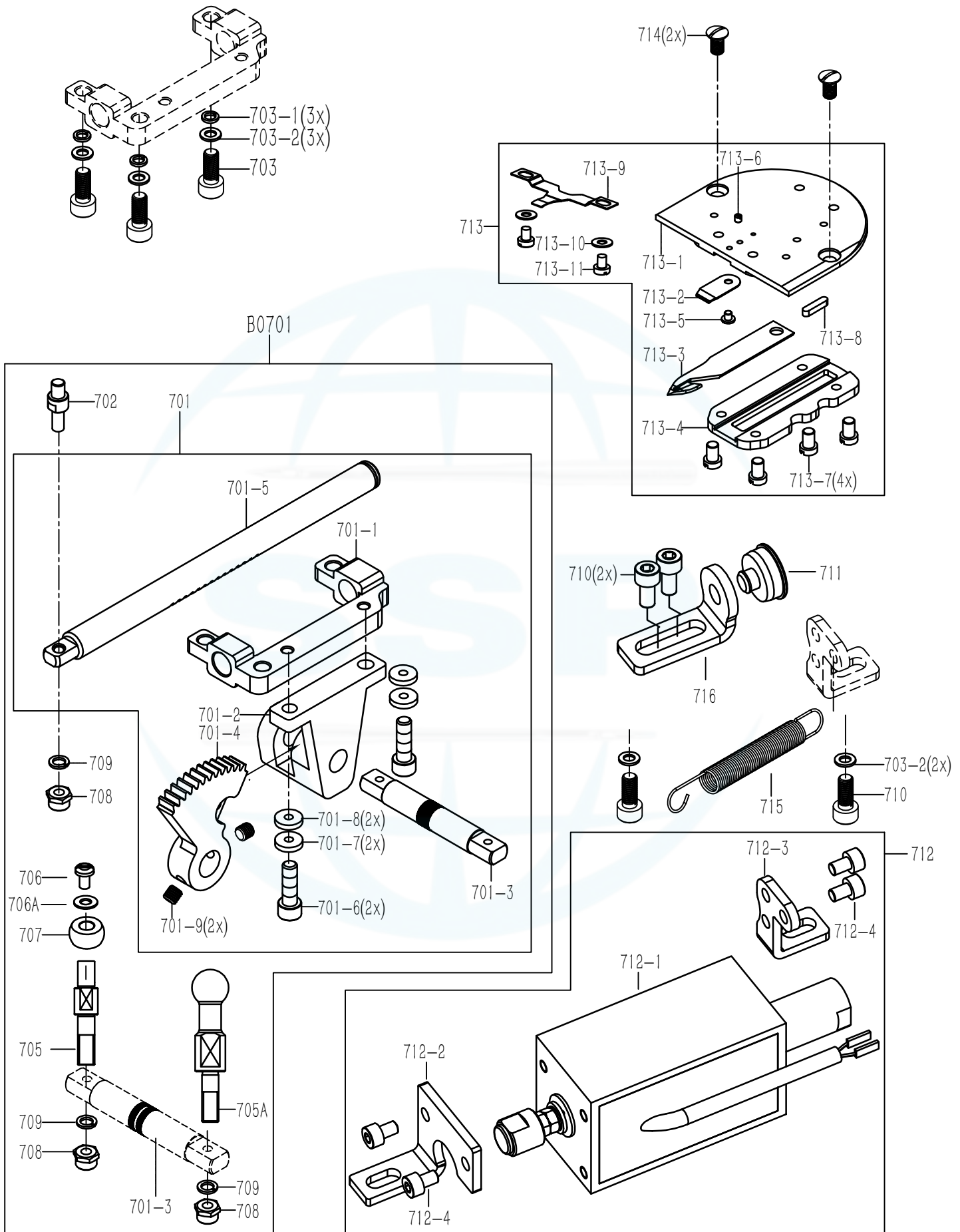

序号	图号	件号	名称	规格型号	数量	
					1530	1530BFT
701	Z5-08-012-00	22122501000	自动剪线齿轮齿条组件		0	1
701-1	Z5-08-012-01	221209010	自动剪线固定座		0	1x
701-2	Z5-08-012-02	221209011	自动剪线轴座		0	1x
701-3	Z5-08-012-03	221202025	剪线传动轴		0	1x
701-4	Z5-08-012-04	221225009	圆柱齿轮72×1		0	1x
701-5	Z5-08-012-05	221202027	自动剪线齿轴		0	1x
701-6	GB/T70.1	S05953	内六角圆柱头螺钉	M5×14	0	2x
701-7	GB/T848	W01146	平垫	M5	0	2x
701-8	GB/T93	W02001	弹垫	M5	0	2x
701-9	GB/T80	S10080	内六角凹端紧定螺钉	M5×6	0	2x
702	Z5-08-034B	221202033	动刀驱动轴销		0	1
705	Z5-08-016G	221202035	自动剪线滚轮轴（短）		0	1
705A	Z5-08-016C	221202034	自动剪线滚轮轴（长）		0	1
706A	GB/T 95	W01144	M3平垫片		0	1
706	GB/T 70.2	S010003	M3x6内六角平圆头(反牙)		0	1
707	Z5-08-039	221224002	钢球φ11		0	1
708	GB/T6172.2	N080001	非金属嵌件六角锁薄螺母	M5	0	3
709	GB/T93	W02001	弹簧垫片	M5	0	3
710	GB/T70.1	S05951	内六角圆柱头螺钉	M5×10	0	4
711	T4-120	155511005	橡皮塞	φ15	0	1
703	GB/T70.1	S05953	内六角圆柱头螺钉	M5×14	0	3
703-1	GB/T93	W02001	弹簧垫片	5	0	3
703-2	GB/T95	W01146	平垫	5	0	5
712	Z5-08-023B-00	22123001200	自动剪线电磁铁组件		0	1
712-1	Z5-08-023B-01	221230012	自动剪线电磁铁		0	1x
712-2	Z5-08-023B-02	221212025	剪线电磁铁固定板A		0	1x
712-3	Z5-08-023B-03	221212026	剪线电磁铁固定板B		0	1x
712-4	GB/T70.3	S05992	内六角圆柱头螺钉	M4*6	0	4x
713	Z5-08-030-00	22121900100	自动剪线刀组		0	1
713-1	Z5-08-030-01	221212013	剪线刀组固定板		0	1x
713-2	Z5-08-030-02B	221219004	定刀		0	1x
713-3	Z5-08-030-03B	221219005	动刀		0	1x
713-4	Z5-08-030-04	221209013	动刀导板		0	1x
713-5	Z5-08-030-05	2212NS10025	定刀锁紧螺钉	M2.5×2.5	0	1x
713-6	Z5-08-030-06	2212NS10024	定刀压力调节螺钉	M2.5×2	0	1x
713-7	GB/T65	S01089	开槽圆柱头螺钉	M4×6	0	4x
713-8	Z5-08-030-08	221223003	润滑毛毡		0	1x
713-9	Z5-08-030-09	221228010	夹线弹片		0	1x
713-10	GB/T 97.1	W01002	平垫圈φ3		0	2x
713-11	GB/T 65	S01601	开槽圆柱头螺钉	M3×4	0	2x
714	Z5-01-017	2212NS17001	开槽半沉头螺丝	SM11/64"-40×9	0	2
715	Z5-08-040B	221227017	自动剪线拉簧		0	1
716	Z5-08-043B	221201010	限位块		0	1

08 供油机构

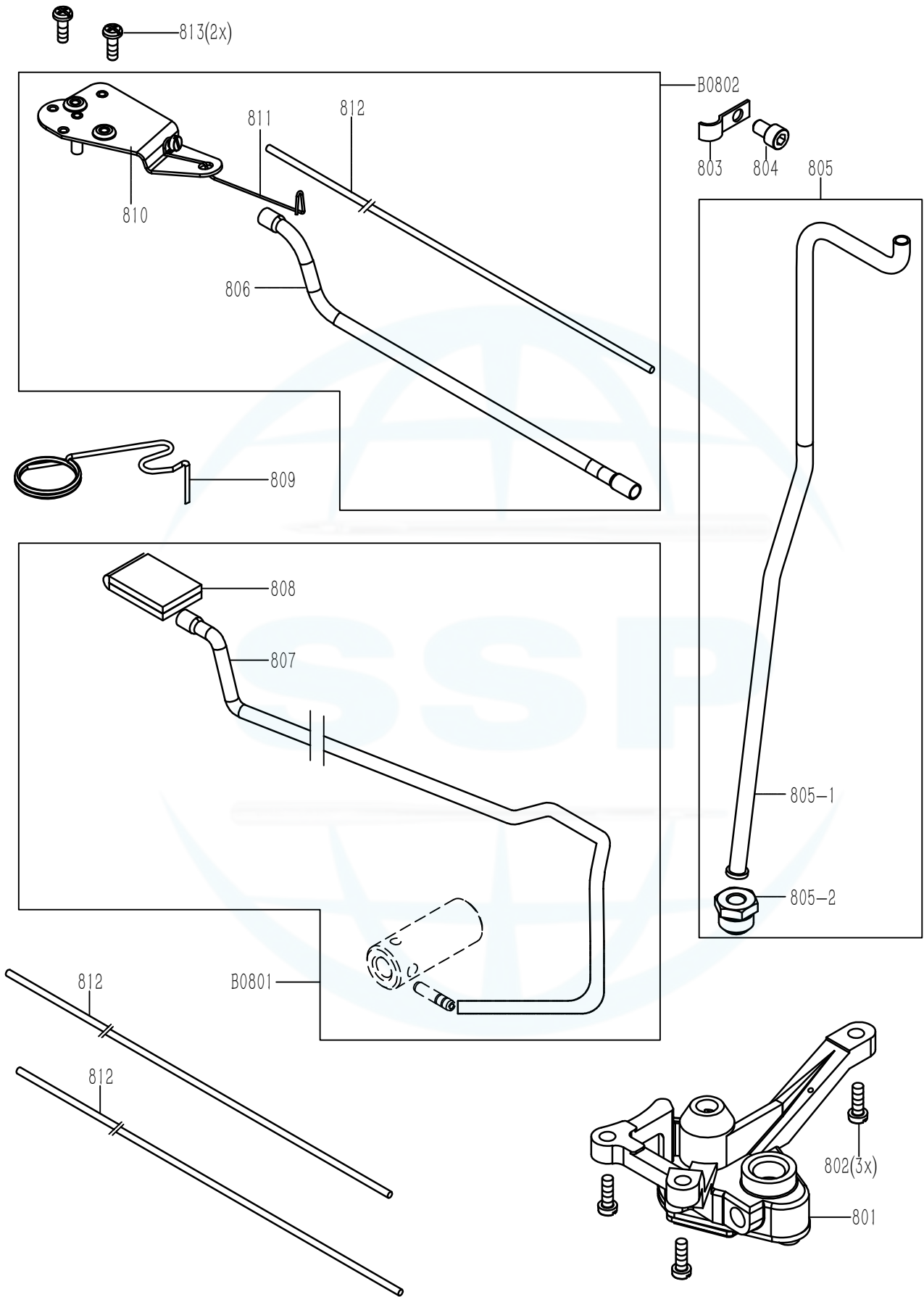

序号	图号	件号	名称	规格型号	数量	
					1530	1530BFT
807	Z5-07-007A	221221007	油管(长)	800mm	1x	1x
808	Z5-07-008	221223001	回油管滤油毡		1x	1x
B0802	Z5-ZJ36	950800410	供油板组件		1	1
806	Z5-07-007	221221004	油管(短)	300mm	1x	1x
810	Z5-07-010-00	22121201700	供油板组件(含钢丝)		1x	1x
811	Z5-07-011	221212018	油线导向钢丝		1x	1x
812	Z5-07-013	221223002	油线		1x	1x
801	Z5-07-001-00	22122000100	油泵组		1	1
802	Z5-05-008	2212NS11003	圆柱头螺丝	SM11/64"-40×12	3	3
803	Z5-07-004	221212007	油管压板		1	1
804		S05609	内六角圆柱头螺丝	M5×8	1	1
805	Z5-07-003-00	22122100500	上轴油管组件		1	1
805-1	Z5-07-003-01	221221003	上轴油管		1x	1x
805-2	Z5-07-003-02	221221002	油管接头	SM1/2"-28 G-53	1x	1x
809	Z5-07-009	221227008	油棉压簧		1	1
813	Z5-07-014	2212NS10022	圆柱头螺钉	SM9/64"-40×11	2	2

SSP



09 随机附件

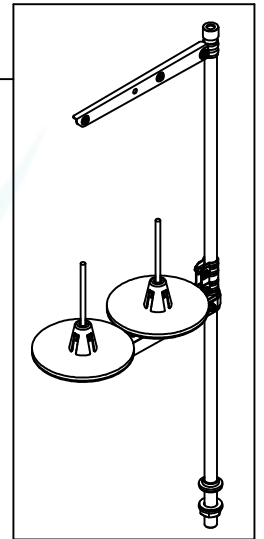
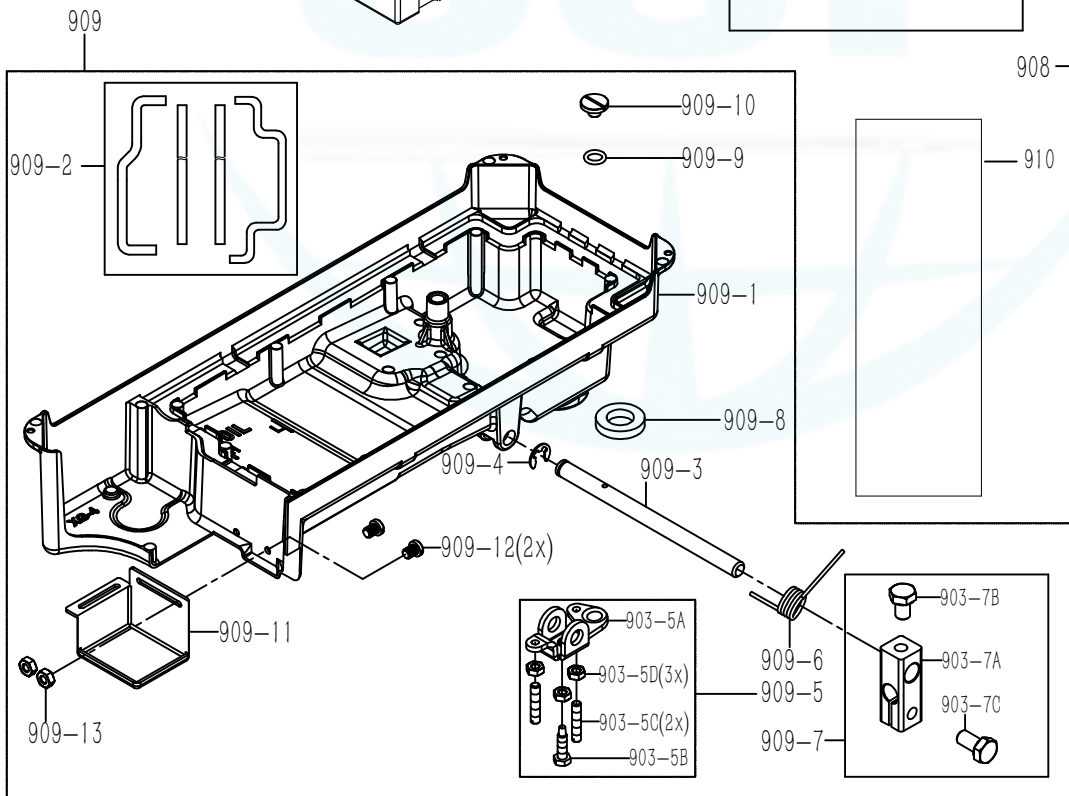
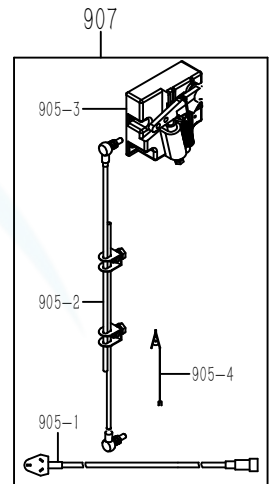
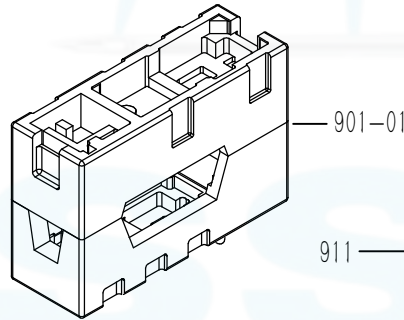
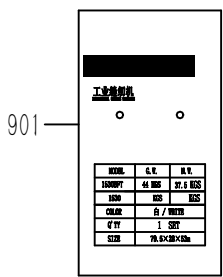
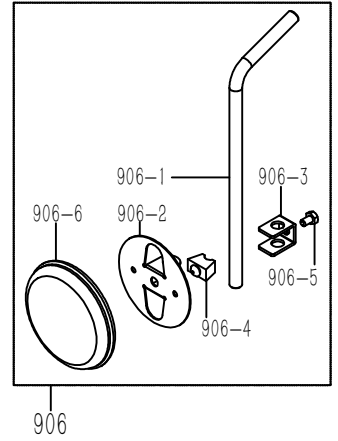
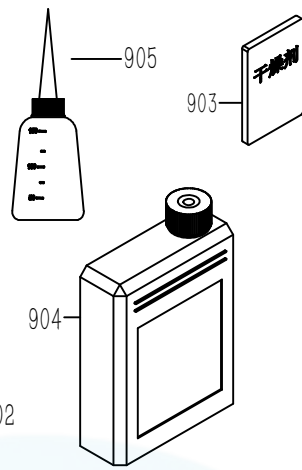
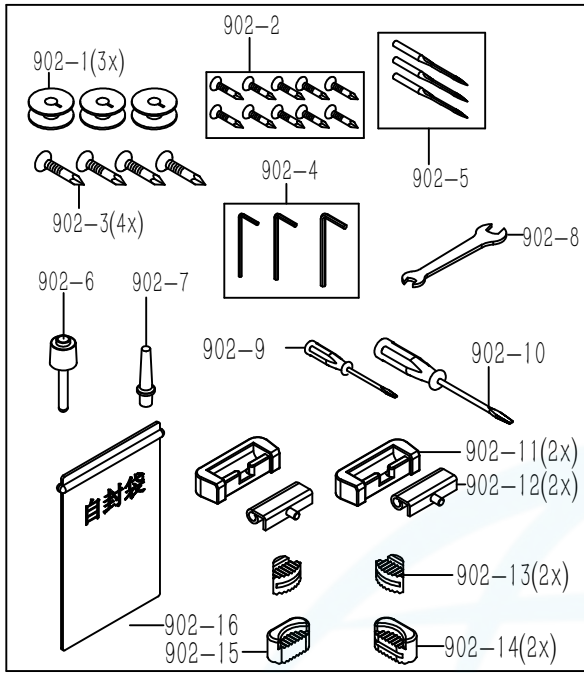

序号	图号	件号	名称	规格型号	数量	
					1530	1530BFT
901	JK-1530-ZX	155831009	1530纸箱		1x	1x
901	Z5-09-021Z	221231028	纸箱(中性)			
901-01	Z5-09-033	22123101400	1530BFT泡沫组件		1x	1x
901-02	A5-1311	115031022	机头罩		1x	1x
901-02	Z5-09-026Z	221231027	机头罩(中性)			
902		155231037	工具包(用自封袋5#装)		1x	1x
902-01	Z5-03-054	221231015	梭芯		3x	3x
902-02	YB/T5002	155226001	圆钢钉	8分	10x	10x
902-03	GB/T845	S16017	十字槽沉头木螺钉	5*25	4x	4x
902-04		155231090	内六角扳手	1.27	1x	1x
		155031002	内六角扳手	2.5	1x	1x
		155031003	内六角扳手	3	1x	1x
902-05		155217001	车针	TNC/DP*5*16#	3x	3x
902-06	Z5-09-004	221211003	膝控提升顶杆		1x	1x
902-07	Z5-09-005	221211004	机头支柱		1x	1x
902-08		114712003	开口扳手	14-10	1x	1x
902-09		155031006	ASD003螺丝起子(小)		1x	1x
902-10		155031007	ASD002螺丝起子(中)		1x	1x
902-11	Z5-09-009	221222016	机头铰链套(后钮胶)		2x	2x
902-12	Z5-09-008	221212015	机头铰链(铁后钮)		2x	2x
902-13	Z5-09-011	221222017	机头防震橡胶垫(小)		2x	2x
902-14	Z5-09-010	221231008	机头防震橡胶垫(大)1		1x	1x
902-15	Z5-09-022	221231009	机头防震橡胶垫(大)2		1x	1x
902-16		155231037	自封袋5#		1x	1x
903	9608-F002	155231039	硅胶干燥剂		5x	5x
904	Z5-09-023-00	22123100300	油壶组件		1x	1x
905	Z5-09-024	221211007	小嘴油壶		1x	1x
906	Z5-09-002-00	22121200800	膝靠组		1x	1x
907	Z5-08-003J-00	22123001800	电控附件(直驱)		1x	0
907	Z5-08-003-00	22123001100	电控附件(三自动)		0	1x
908	MLK-H3030-01-011	22081233000	线架组件		1x	1x
909			油盘组件		1	1
909-1	Z5-09-003	221222014	油盘(兴港4号)		1x	1x
909-2	Z5-09-006	221228009	油盘垫		1x	1x
909-3	Z5-09-014	221202030	膝控铰链轴		1x	1x
909-4	GB/T896	H05010	开口挡圈	ø9	1x	1x
909-5	Z5-09-017-00	22120901600	膝控限位架组件		1x	1x
909-6	Z5-09-015	221227015	膝控复位弹簧		1x	1x
909-7	Z5-09-013-00	22121600400	抬压脚操纵杆接头组件		1x	1x
909-8	Z5-09-007	221247001	油盘磁铁		1x	1x
909-9	Z5-04-010	221222011	O型圈		1x	1x
909-10	Z5-09-020	2212NS10026	排油孔螺钉		1x	1x
909-11	Z5-09-030	221220002	接油盆		1x	1x
909-12	GB/T70.1	S05952	内六角圆柱头螺钉		2x	2x
909-13	GB/T6170.2	N06017	六角薄螺母	M5	2x	2x
910		220131006	五层纸板700x150		1	1
911		221231010	PE袋		1	1
912	JK-6691-F036	155231020	合格证		1	1
		155231041	挂牌绳(挂合格证用)		1	1
	JK-08-002-01	221237002	二维码标签纸		1	1

10 电控部分

